

1. GENERAL INFORMATION

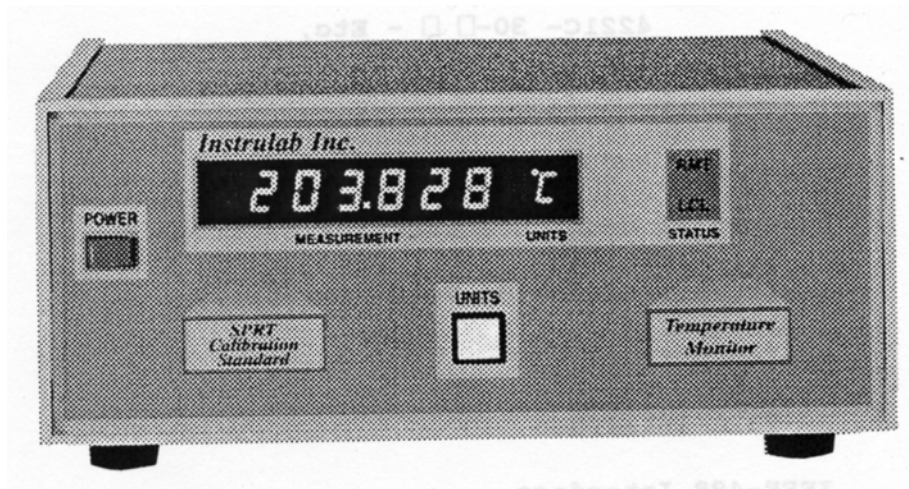

1.1 FEATURES

The Instrulab Inc. model 4221C Programmable RTD Temperature Monitor utilizes microprocessor technology to produce a stable, high accuracy instrument with simple "customized" calibration capability. "Customized" calibration provides the ability to digitally calibrate the instrument to match the specific calibration curve of a calibrated RTD to optimize system accuracy. The use of non-volatile Random Access Memory allows the instrument to be easily programmed by simply entering the RTD sensor coefficients into memory.

The outstanding features of the Model 4221C include:

- Programmable Calibration
- Either Front Panel or Terminal Control
- Extremely Accurate; $\pm 0.005^{\circ}\text{C}$ (-189 to $+300^{\circ}\text{C}$)
- Wide temperature Range; -218°C to 660°C
- $^{\circ}\text{C}$ or $^{\circ}\text{F}$ or Ohms
- Resolution and Repeatability of 0.001° and 0.0001 ohms.

1.2 INSTRUMENT IDENTIFICATION AND OPTIONS

The instrument model number, serial number and other pertinent data is given on the rear of the instrument. The model number will appear as:

4221C - 30 - □ □ - Etc.
Model Options

Option number	Description
06	Rack/Panel Mount Brackets (pair)
07	Instrument Wired 230 Volt Operation.
08	Analog Output
14	RS-232C Interface
15	IEEE-488 Interface
30	Large Gold-Plated Studs (Normally Standard)

1.3 TECHNICAL SPECIFICATIONS

(See options on page 2)

Instrument Range	-218.000°C to +660.000°C or -360.000°F to +1220.000°F or 0.0000 to 110.0000 Ohms
Instrument Accuracy, @23°C±2°C Calibration in Accordance with ITS-90	± 0.003°C to 0.007°C (±0.006°F to 0.014°F) depends on the temperature being measured (See Page 5) ±3 PPM + 0.0003 ohms
Calibration Check Interval	1 year
Resolution and Repeatability	0.001° on both °C and °F scales, 0.0001 on Ohms scale
Excitation Current	1 milliamp DC (nominal)
Sensor Type	Platinum RTD Ro=25.5 Ohms. Alpha (nominally) 0.003925
Sensor Coefficients	Rtp plus the required sensor coefficients, the number of which are dependent on the sub-range.

Operating Ambient Temp.	+15° to +35°C
Non-operating Ambient Temp.	-10° to +55°C
Humidity	Less than 75% noncondensing
Warm-up Time	Within specifications in 15 minutes, optimum performance after 2 hours.
Temperature Coefficient (Reference 23°C ambient)	± 2 PPM + 0.00005 Ohms/°C
Display	0.4" high red LEDs: six digits plus °F/Ohms/°C symbol and polarity indicator. "Local" or "Remote" control status
Display Update	Approximately once per second
Display Overrange	Display reads EEEEEEE for input over 110 Ohms
Weight	Net 9 lbs. (4 kg) Shipping 12 lbs. (5 kg)
Power	115 VAC standard, 230 VAC optionally, 50/400 Hz, 12 VA nominal, supplied with a eight foot 3 wire line cord.
Size	3 1/2" High x 8 1/2" Wide x 11 3/8" Deep, Half Rack

INSTRULAB MODEL 4221C INSTRUMENT UNCERTAINTY WHEN USED WITH A
 PLATINUM RTD WHICH HAS THE FOLLOWING CHARACTERISTICS:

Ro = 25.5 ohm (nominal) ALPHA =0.003925

MEASURED TEMPERATURE		OHMS (NOMINAL)	INSTRUMENT UNCERTAINTY IN:		
°C	°F		OHMS	°C	°F
-218	-360	2.4	±0.0003	±0.012	±0.022
-190	-310	5.6	0.0003	0.003	0.005
-100	-148	15.2	0.0004	0.003	0.006
0	+32	25.5	0.0004	0.004	0.007
100	212	35.6	0.0004	0.004	0.007
200	392	45.3	0.0004	0.005	0.008
300	572	54.8	0.0005	0.005	0.009
400	752	63.9	0.0005	0.006	0.010
500	932	72.7	0.0005	0.006	0.011
600	1112	81.3	0.0005	0.006	0.012
660	1220	86.3	0.0006	0.007	0.012

1.4 WARRANTY

Instrulab warrants its products to be free from defects in material and workmanship for one year after date of shipment, provided the units have been used within published ratings. The warranty is limited to our repairing or replacing without charge, F. O. B. our factory any defective product if returned to our plant, transportation prepaid. No other representation or warranty, either expressed or implied, is made, and in no event shall Instrulab be liable for consequential or other damages.

1.5 UNPACKING AND SHIPPING

After having unpacked the instrument, carefully examine it and any enclosed accessories for physical damage and compliance with the packing list. If any of the articles are missing or damaged, inspect the packing case for signs of damage or theft during shipment and immediately report it to the carrier.

If it should become necessary to return the instrument to Instrulab Inc., use the original packing material, if possible.

When returning instruments to the factory, give a full description of the failure and the mode of operation that was used when the instrument failure occurred. Please include the name and phone number of someone we can contact, should we have any questions. Ship via UPS or parcel post prepaid to:

Instrulab Inc.
1205 Lamar Street
Dayton, Ohio 45404

1.6 PRELIMINARY CHECK-OUT

Please use the following procedure before applying power for the first time:

1. Remove the two top screws at the rear of the case.
2. Slide the top cover to the rear to inspect the instrument.
3. Verify that the vertical board(s), Display Board and Option board(s) and their cables are properly seated in their connectors.

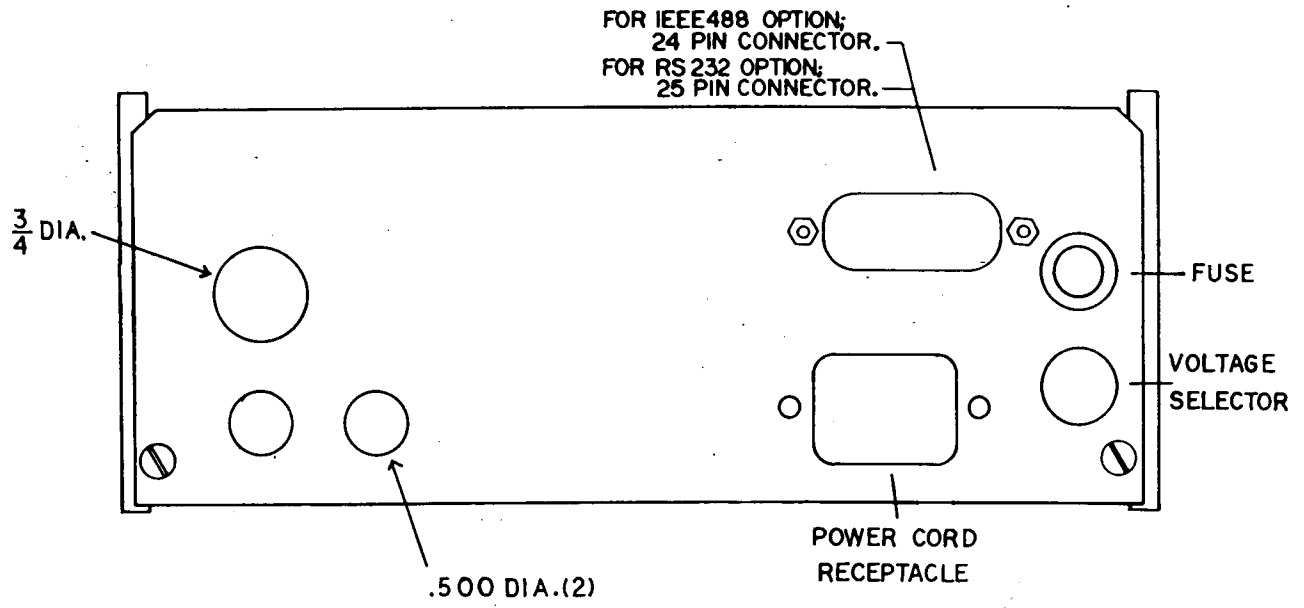

BACK VIEW

Case Outline Drawing

Figure 1a

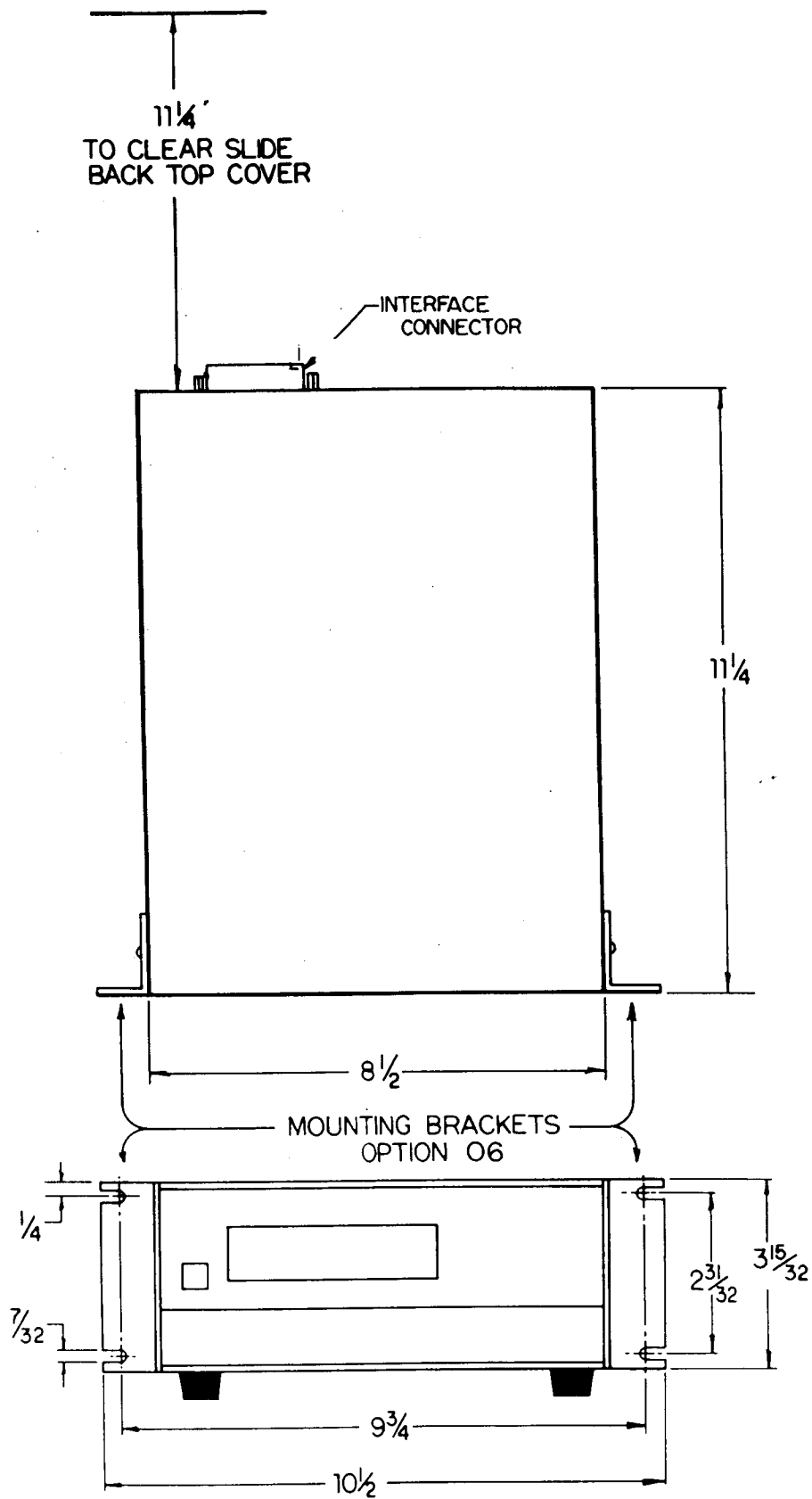

Case Outline Drawing

Figure 1b

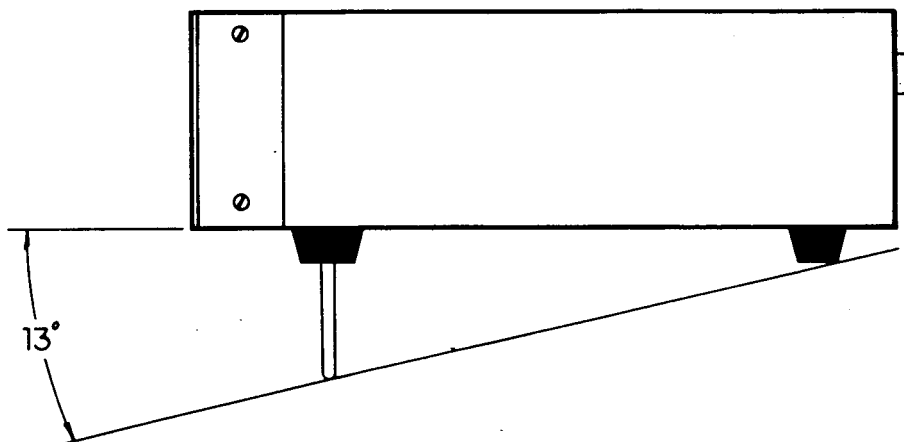
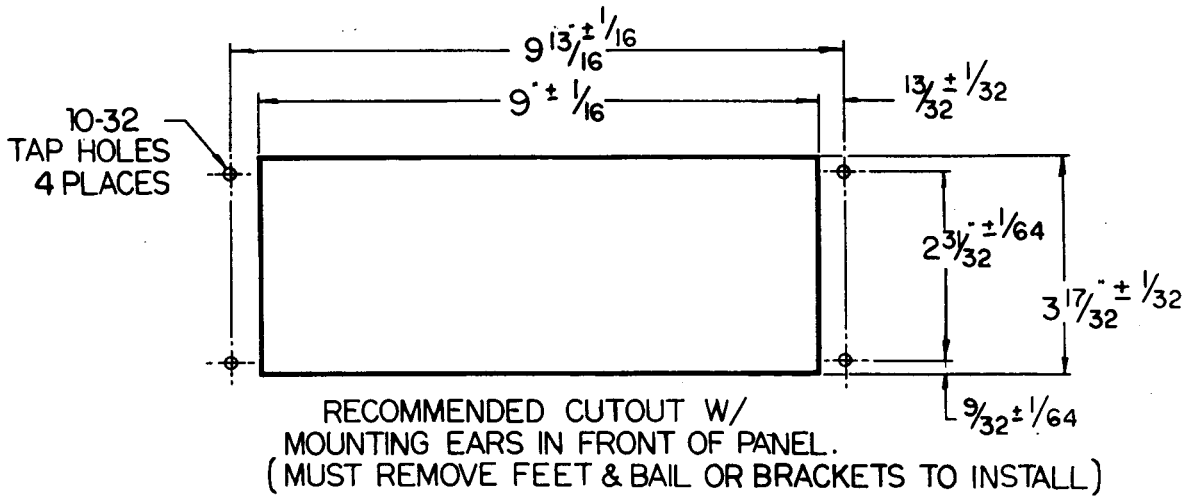
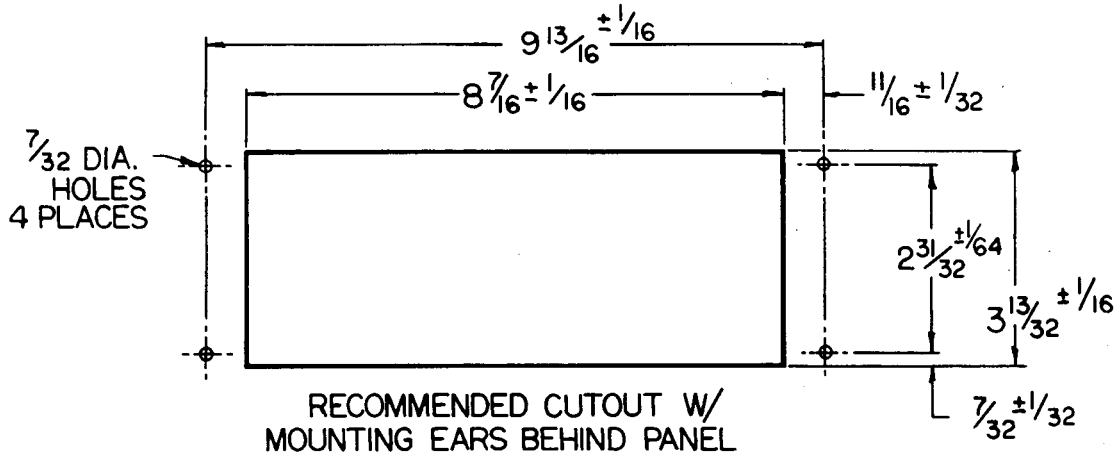

Case Outline Drawing

Figure 1c

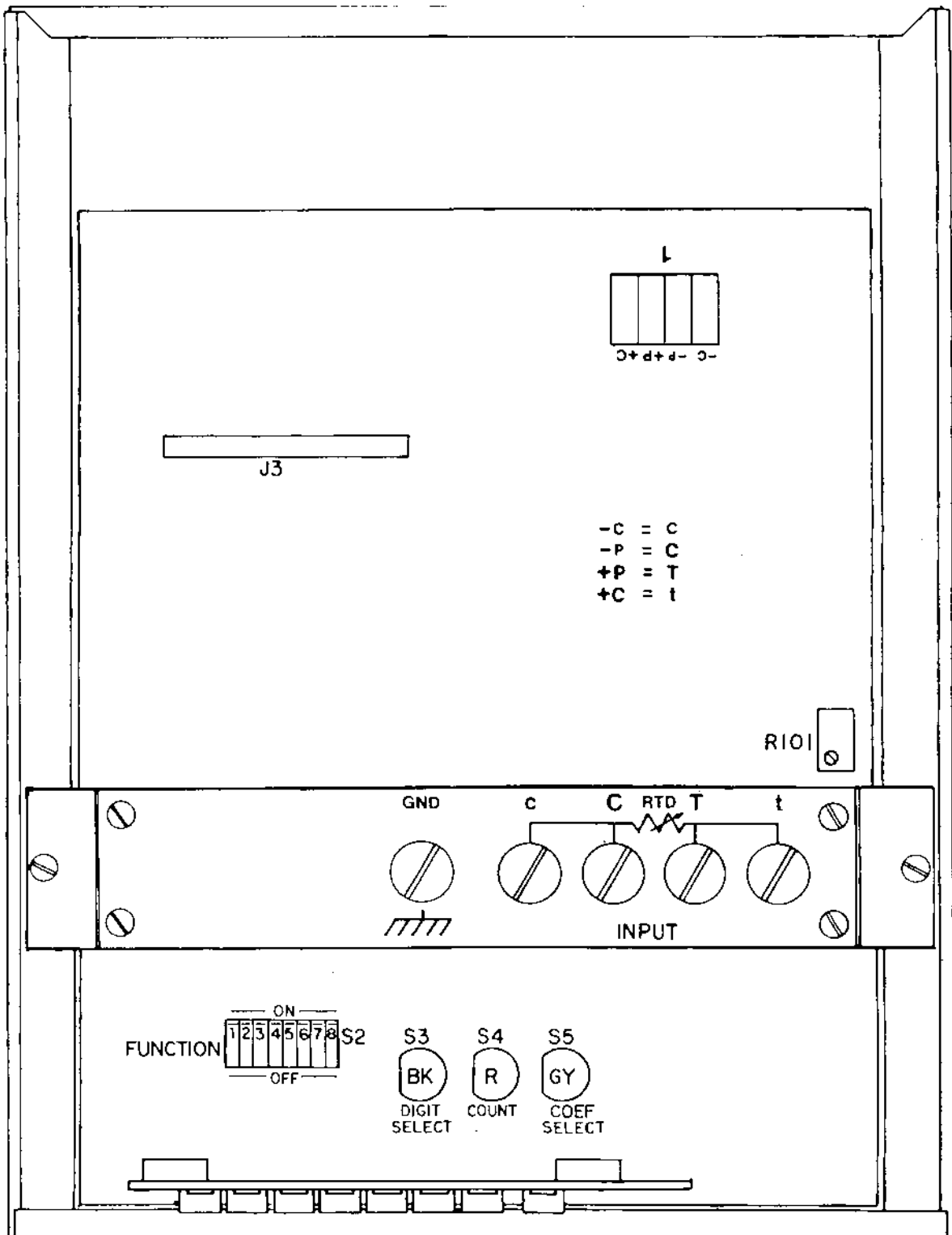

Top View of Instrument Showing Programming Switches

Figure 2

2. STANDARD OPERATION

2.1 SENSOR CONNECTION

Sensors are connected to a terminal strip that is located directly under the top cover of the instrument.

To connect the sensor leads, remove the top cover, insert the leads through the hole in the back panel and connect to the four terminals as shown on the terminal strip diagram. The terminals are marked c, C, T, and t. If your sensor leads are marked with the letters c, C, T, and t such as the Rosemount model 162CE, simply connect to the terminals, as indicated. If your sensor has four unmarked leads, connect the two leads with a common connection to the C & c terminals and the other two leads to the T and t terminals. The order is not important, just as long as the leads with the common connections are connected to the leads with a common letter. Interchanging of leads C & c and T & t will not affect the instrument's accuracy. Failure to use a four lead system will result in a reading error.

If OPTION 30 (Gold Plated Studs) was not supplied with the 4221C, Connect the sensor to the terminal strip mounted at the right rear of the Master PC Board. Match the markings on the sensor leads to the markings on the terminal strip. If your sensor is marked C,c,T,t, see figure 2 page 10 for cross reference.

2.2 POWER CONNECTION

The standard model is designed to operate 115 VAC +10%. Models designed for 230 VAC operation contain the option number 07. We recommend that a 3 wire U-ground receptacle be used. The instrument is within rated specification within 15 minutes..Optimum performance is obtained after 2 hours.

When the instrument is first turned on, the display will read "ItS-90", then it will light all segments, along with all decimal points. Then, if Option 14 is installed, it will read "rS-232" or, if Option 15 is installed, it will read "IEEE 07". The two numbers are the instrument address. Instrument will then commence to read sensor input.

2.3 MATCHING THE INSTRUMENT TO A SPECIFIC SENSOR

2.3.1 IDENTIFYING ITS-90 SUBRANGES AND COEFFICIENTS

1. Instrument can be programmed for any range or sub range that falls within the limits of:

218.7916°C (TP of Oxygen) to +660.323°C (FP of Aluminum)

2. The actual range depends on the calibration of your sensor and may be negative temperatures, positive temperatures or a combination of both.
3. The following table lists the "a, b & c" coefficients for various sub ranges that may be programmed into the instrument.

LOWEST CALIBRATION TEMP. °C		HIGHEST CALIBRATION TEMP. °C		INSTRULAB ASSIGNED COEFFICIENT IDENTIFICATION						
°C	°C	°C	°C	0	1	2	3	4	5	6
	0.00	to	660	Rtp	a7	b7	c7	-	-	-
	0.00	to	419	Rtp	a8	b8	0	-	-	-
	0.00	to	231	Rtp	a9	b9	0	-	-	-
	0.00	to	156	Rtp	a10	0	0	-	-	-
-38	to +0.01	to	29	Rtp	a5	b5	0	-	-	-
-189	to +0.01			Rtp	-	-	-	a4	b4	0
-218	to +0.01			Rtp	-	-	-	a3	b3	C1

Rtp = Resistance of sensor at the triple point of water, i.e. +0.01°C.

2.3.2 FORMATTING THE ITS-90 COEFFICIENTS

1. The coefficients received with your sensor should appear similar to the following example.

SAMPLE #1: Sub range = -189 to +419°C (500°C)

```
Rtp = 25.49771 ohms
a4 = -1.2489735E-04
b4 = -7.0887999E-06
a8 = -1.5846712E-04
b8 = 1.6725899E-06
```

2. Entry of Rtp is directly as listed, be sure to observe the decimal point.

3. The required format for coefficient entry is as follows:

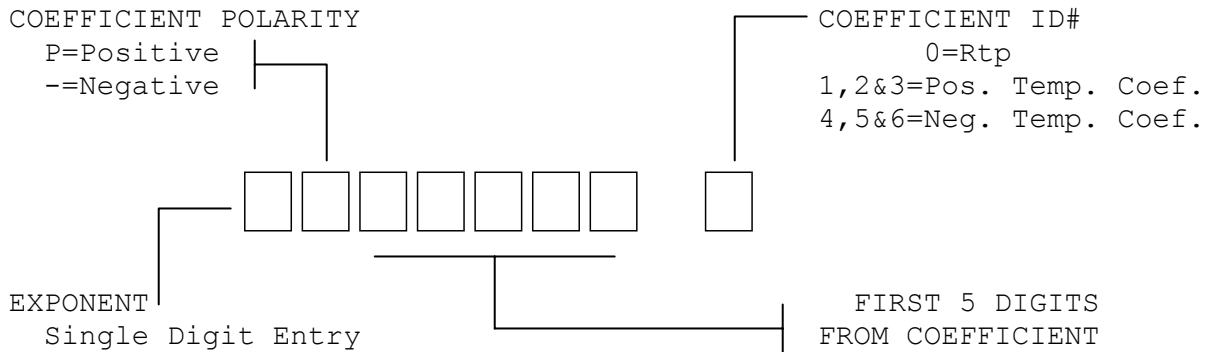

Note that correct formatting of the Coefficients requires the relocation of only the exponent to the beginning of the string.

2.3.3 PROGRAMMING THE COEFFICIENTS INTO MEMORY

First remove the two top cover retaining screws and slide Off the top cover, then turn on the power. A warm-up period is not necessary since only the digital constants are being programmed. Now Locate the FUNCTION switch and the BLACK, RED and GRAY pushbutton switches, near the front of the instrument. (See figure 2 for component Locations.

At this time, (prior to programming) the FUNCTION switch, positions #1 and 2 should be in the "off" position. See Figure 3.

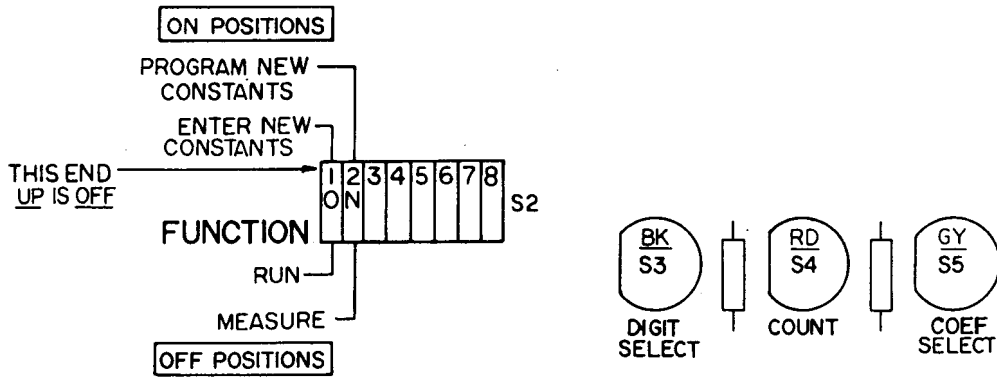

Close up of S2 Showing Sensor Coefficient Programming Switches

Figure 3

1. Move the FUNCTION switch, position 2 to the "on" position. A small number "0" should appear in the far right hand side of the digital display. This indicates that Rtp, is ready to be programmed. You will also note that the far left hand digit is flashing This indicates that this digit will accept a change in numerical value. Use the RED COUNT button to change this digit to the number desired.
2. After the first digit is programmed, advance to the second digit by pressing the BLACK DIGIT SELECT button. The second digit should now flash. Now program the number for this digit just like the first digit, using the RED COUNT button.
3. Now program the rest of the digits using the BLACK and RED buttons, until all digits have been programmed.
4. To move to the next constant, press the GRAY COEF SELECT button. The number "1" should appear in the far right hand side of the display and the first digit should be flashing.
5. Proceed using the GRAY, RED, and BLACK push buttons until all coefficients are programmed. You will notice that each time the GRAY button is pressed, the number at the far right hand side will change, from 1 to 2 to 3, etc. until all coefficients have been programmed.
6. After all coefficients have been programmed, press the GRAY button once more. All digits should stop flashing and the instrument should indicate "rEAdY".

NOTE

If you are aware of an error in programming one or more of the coefficients, continue with the programming procedure, then go back through the procedure a second time and make your changes. This technique allows you to retain the coefficients that are correct and change only those coefficients that are incorrect.

7. Go back to the FUNCTION switch, S2, and move position 1 to the "on" position and then move it back to the " off" position. The display will read "buSY". After about 1 second, the display should change to "donE".

During the 1 second pause, the instrument programs the sensor coefficient data, that you programmed, into the non-volatile memory and checks to see if the information was programmed properly. If it was programmed properly, the instrument will respond with the word "donE" on the display. If the data was not programmed properly, a number followed by the word "Error" will appear on the display. if this should happen, turn the instrument " off" then back "on" again and return to step 1 and repeat the entire programming procedure again.

8. After the instrument has told you that it is "done", move the FUNCTION switch, position 2, to the " off" position. Make sure that position 1 is also in the " off" position at this time. The instrument should now be reading the temperature of your sensor.

2.3.4 PROGRAMMING EXAMPLES:

SAMPLE #1: Sub range = -189 to +419°C (500°C)

Rtp = 25.49771 ohms
a4 = -1.2489735E-04
b4 = -7.0887999E-06
a8 = -1.5846712E-04
b8 = 1.6725899E-06

Using the sample coefficients listed above, their entry would appear as follows:

- .1 Turn on instrument
- .2 Operate SW #2 of S2 to ON
- .3 Enter Rtp using "DIGIT SELECT" and "COUNT" buttons.
- .4 Press "COEF SELECT" button
- .5 Enter a8 using "DIGIT SELECT" and "COUNT" buttons
- .6 Press "COEF SELECT" button
- .7 Enter b8 using "DIGIT SELECT" and "COUNT" buttons
- .8 Press "COEF SELECT" button
- .9 There is no c coefficient for this sub range. Enter as zeros using "DIGIT SELECT" and "COUNT" buttons
- .10 Press "COEF SELECT" button
- .11 Enter a4 using "DIGIT SELECT" and "COUNT" buttons
- .12 Press "COEF SELECT" button
- .13 Enter b4 using "DIIGIT SELECT" and "COUNT" buttons
- .14 Press "COEF SELECT" button

- .15 There is no c coefficient for this sub range. Enter as zeros using "DIGIT SELECT" and "COUNT" buttons
- .16 Press "COEF SELECT" button
- .17 Enter your sensor serial number
- .18 Press "COEF SELECT" button
- .19 Enter your sensor Calibration or Calibration Due date
- .20 Press "COEF SELECT" button
- .21
- .22 Operate SW #1 of S2 to ON. Entries are now being programmed into memory
- .23 When display reads "done" operate SW #1 & #2 of S2 to OFF
- .24 Programming is now complete.

For details on realizing the ITS-90, changes from the IPTS-68, differences between T90 and T68 (and T76), and means of approximating the ITS-90, see NIST Technical Note 1265, entitled "Guidelines for Realizing the International Temperature Scale of 1990 (ITS-90)", by B. W. Mangum and G. T. Furukawa.

THIS PUBLICATION IS AVAILABLE FROM:

NIST
 Office of Publications and Programs Inquiries
 Room E128, Administration Building
 Gaithersburg, MD 20899
 (301) 975-3058

2.4 CHECKING SENSOR COEFFICIENTS

1. Operate "FUNCTION" switch position 2 to "ON".
(See Fig. 3)
2. "0" constant is displayed. 0=Rtp.
3. Operate the gray "COEF SELECT" pushbutton and note the constant that is displayed each time the pushbutton is depressed.
4. Operate "COEF SELECT" pushbutton after menu "8" is displayed. All blinking should stop. Instrument reads "READY".
5. Operate "FUNCTION" switch 2 to " OFF". Instrument will commence reading sensor input.

2.5 CHECKSUM VERIFICATION of PROGRAMMED VARIABLES

The 4221C insures the integrity of the programmed variables stored in the Zero Power RAM (ZPRAM) by the use of checksums. The checksum for each set of variables is programmed into the ZPRAM when the set of variables is programmed. Then, each time the instrument is turned on, the checksum of each set of variables is computed and compared to programmed checksum. In the case of an error, the 4221C displays a message, as below, to indicate which set of variables needs to be reprogrammed and waits until the variables have been checked.

P	r	o	g			1	
---	---	---	---	--	--	---	--

 = Sensor Coefficients

This indicates there is an error in the Sensor coefficients or the Zero offset Correction. the 4221C will display "Prog 1" until FUNCTION switch, Position 2 is moved to the ON position. Refer to 2.3.3 of the manual for programming instructions for the Sensor Coefficients and 4.1.2 for verification of Zero offset Correction.

If the Sensor Coefficients and Zero offset Correction are checked without being reprogrammed, (Refer to 2.4 and 4.1.2.1, both of the 4221C manual), resistance reading and the temperature readings may be incorrect and the "Prog 1" message will be displayed the next time the instrument is turned on.

P	r	o	g	I	E	E	E
---	---	---	---	---	---	---	---

 IEEE-488 Interface Address

This indicates there is a problem with the IEEE-488 primary address. The 4221C will display "Prog IEEE" until FUNCTION switch, position 3, is moved to the ON position. Refer to 3.2 of the manual for programming instructions for the IEEE-488 primary address.

If the primary address is checked without being reprogrammed, the instrument will read resistance and temperature correctly but the interface may not work and the "Prog IEEE" message will be displayed the next time the instrument is turned on.

P	r	o	g	2	3	2	
---	---	---	---	---	---	---	--

 = RS-232C Interface parameters

This indicates there is a problem with the RS-232C Interface parameters. The 4221C will display "Prog 232" until FUNCTION switch, position 3 is moved to the ON position. Refer to 3.1 of the manual for programming instructions for the RS-232C interface parameters.

If the parameters are checked without being reprogrammed, the instrument will read resistance and temperature correctly, but the interface may not work and the "Prog 232" message will be displayed the next time the instrument is turned on.

3. OPTIONS

Remove Power before Proceeding.

Before using the remote option, remove the top cover and check to ensure that the vertically mounted remote option card is securely plugged in and that the internal cable is connected.

3.1 RS-232C INTERFACE (Option 14)

The RS-232C option on the model 4221C can be used with either a printer or a computer using terminal emulation software or application software:

Operation with a Printer

In this configuration, a switch in the 4221C controls if readings are sent directly from the 4221C to a printer or a computer using terminal emulation software. Refer to Section 3.1.2 for further explanation of this configuration.

Operation with a Computer

The 4221C can be interfaced to a computer using terminal emulation software or application software. In this configuration, the following functions are available:

- (1) Read the current 4221C reading
- (2) Select the measurement scale °F the 4221C
- (3) Read current ITS-90 sensor coefficients
- (4) Program new ITS-90 sensor coefficients
- (5) Check Status of the 4221C

Refer to Section 3.1.3 through Section 3.1.3.5 for further explanation of functions available in this mode.

3.1.1 Programming the 4221C Communication Parameters

The communication parameters of the 4221C must match the software:

Baud Rate: The 4221C can be programmed for 110, 150, 300, 600, 1200, 2400, 4800, or 9600 baud.

Data Bits: The 4221C can be programmed for either 7 or 8 bits per character.

Stop Bits: The 4221C can be programmed for either 1 or 2 stop bits.

Parity: The 4221C can be programmed for odd, even, or no parity.

Echo: The 4221C can be programmed for echo on or off.

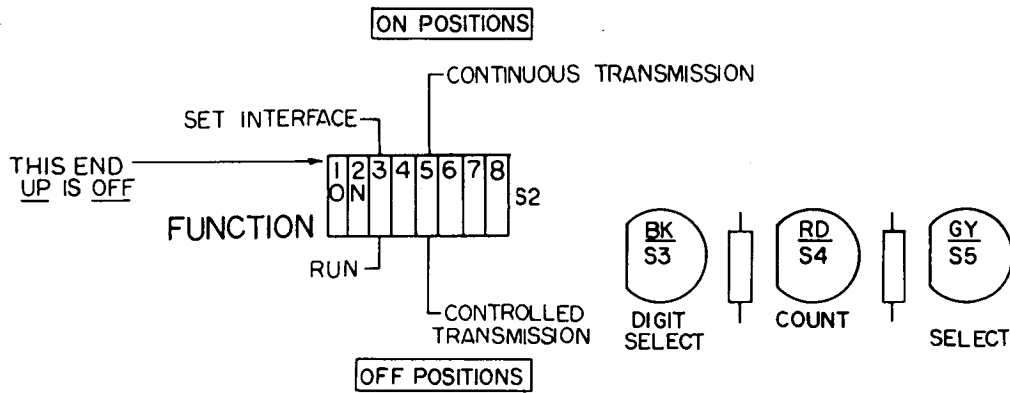

Close Up of S2 Showing RS-232C Switches
Figure 4

Programming the communication parameters:

Refer to Figure 2 and Figure 4 to Locate the programming switches.

Move position 3 of the FUNCTION Switch S2 to the "ON" position to put the 4221C in the SET INTERFACE mode.

The 4221C will display "br" followed by the current baud rate.

To change the Baud Rate, press the red "COUNT" button until the desired baud rate is displayed.

Press the gray "COEF SELECT" button to continue.

The 4221C will display the current number of bits per character, "7 bits" or "8 bits".

To change the number of bits per character, press the red "COUNT" button until the desired number of bits per character is displayed.

Press the gray "COEF SELECT" button to continue.

The 4221C will display the current number of stop bits, "1 StoP" or "2 StoP".

To change the number of stop bits, press the red "COUNT" button until the desired number of stop bits is displayed.

Press the gray "COEF SELECT" button to continue.

The 4221C will display the current parity, "no PAr", "odd PAr", or "EvEnPAr".

To change the parity, press the red "COUNT" button until the desired parity is displayed.

Press the gray "COEF SELECT" button to continue.

The 4221C will display the current Echo selection, "ECHO on" or "ECHO OFF".

Echo on: The 4221C will echo each character it receives back to the computer.

Echo off: The 4221C does not echo characters back to the computer.

To change the Echo selection, press the red "COUNT" button until the desired Echo selection is displayed.

Press the gray "COEF SELECT" button to continue.

The 4221C will display "rEAdy".

To return the 4221C to normal operation without changing the previous communication parameters, return position 3 of the FUNCTION switch to the "OFF" position.

To program the 4221C with the new communication parameters, move the FUNCTION switch S2 position 1 to the "ON" (Program New Coefficients) position.

The 4221C will display "donE" after the new parameters are programmed. Return the FUNCTION switch S2 positions 1 & 3 to the " OFF" position to return the 4221C to normal operation.

Note: If the 4221C displays "Error", turn the 4221C off and then on and perform programming steps again.

3.1.2 Operation with a Printer

The 4221C may be connected to a printer or a computer using terminal emulation software.

The sending of readings can be controlled by FUNCTION switch S2 position 5, see Figure 4.

When the switch is in the " OFF" position, no readings are sent.

When the switch is in the "ON" position, a reading will be sent each time the 4221C updates the display, approximately once per second. See Section 3.1.3.1 for the reading format.

The sending of readings can also be controlled by commands sent over the interface. Type "E1" followed by <CR><LF> to turn continuous transmission on. Type "E0" followed by <CR><LF> to turn continuous transmission off. See Section 3.1.3 for more information on sending commands.

3.1.3 Operation with a Computer

When the 4221C is used with a computer using terminal emulation software or application software, the functions listed in the Summary of 4221C RS-232C Commands are available. In the following descriptions of the RS-232C commands, their use is illustrated using example programs written in LabVIEW. The following explanations are provided to help in using the 4221C with other programming languages.

Programming Notes

1. Be sure to match the communication parameters of the 4221C and your hardware/software combination. Use the Serial Port Init VI to program the communication parameters to match the parameters set on the 4221C.

The Serial Port Init VI is found in Functions / Instrument I/O / Serial. You probably will not need the "Flow Control Etc." Control box. If you do, right click on the connection and create control.

2. The 4221C uses data messages to chose "Local" or "Remote" selection of measurement scale/channel. When "Remote" selection is chosen, the front panel switches are ignored.

- 3 The data terminator for output to the 4221C can be a Carriage Return <CR>, a Line Feed <LF>, or a <CR><LF>. The data terminator for input from the 4221C is a <CR><LF> ">" <CR>><CF>.

If you have problems with the computer hanging up, check the data terminators.

Another cause for the 4221C hang up is overloading the 4221C. Overloading the 4221C is caused by rapid repeating commands to the 4221C. It takes CPU time for the 4221C to transmit serial data. If too much time is demanded by the serial communications port the 4221C will hang up. The most common cause of this is rapidly repeating the status to see when the 4221C has updated.

4. It is possible to reset the 4221C to the power-on state by sending it a "^C". To send the 4221C the "^C" use Concatenate Strings VI to append the string end of line constant to a string constant of "03". Both these are found in Functions/String. Use the Serial Write Function to send the concatenated string to the 4221C. The Serial Write VI is found in Functions/Instrument I/O and Serial.

ALL COMMANDS ARE UPPER CASE.

5. Two character commands, such as "RC", are two consecutive characters and may not be separated by a space. All commands must have an end of line termination which is a line feed and carriage return. The end of line string constant is found in Functions/String.
6. Programming note 4 above explains how to append the end of line constant to the Command.
7. The procedure for reading and displaying a reading is in the next section.

3.1.3.1 Readings from the 4221C

If the 4221C is not in the Read ITS-90 Coefficients mode or the Program ITS-90 Coefficients mode, it will send the currently displayed reading when it receives a "T". The data is sent from the 4221C as the reading with leading polarity sign, followed by a space, a character for the measurement scale (C, F or O for Ohms) then the data terminator: [Note the > after the first <LF>.]

```
+138.500 O1<CR><LF>><CR><LF>
  or
+0100.00 C1<CR><LF>><CR><LF>
  or
+0212.00 F1<CR><LF>><CR><LF>
```

To display the current reading of the 4221C use the following LabVIEW™ steps. A 500 ms delay is in each of the following routines.

- Send a "T" string with the end of line terminator appended as explained in programming note four (4) of section 3.1.3.
- Use the "bytes at serial port" VI to ascertain the number of bytes the 4221C has sent. This VI is found in Functions/Instrument I/O and Serial.
- Connect the "byte count" terminal of the above terminal to the "Serial Number of Bytes read" to the "Serial Port Read" VI found in Functions/Instrument I/O and Serial.
- Add an indicator to the Data Read port of the "Serial Port Read" VI for the reading.
- Enlarge the indicator to display all the lines received with the prompt ">".
- Hint: You can chose not to display the prompt ">" by using the "Split String" VI (In Functions/String) between the Serial Read and the reading indicator. Use ">" as the "Search Char"

3.1.3.2 Selection of Measurement Scale

4221C REMOTE / LOCAL COMMANDS

COMMAND

RC	Selects Celsius measurement scale
RF	Selects Fahrenheit measurement scale
RO	Selects Ohms (resistance) measurement scale
L	Returns selection of the measurement scale to the front panel switch.

After power-on reset initialization, the measurement scale of the 4221C is selected from the front panel. Sending a Remote command ("RC", "RF" or "RO") to the 4221C selects the measurement scale and overrides the front panel switch. Selection of the measurement scale can be returned to the front panel switch by sending a Local command ("L").

3.1.3.3 Reading ITS-90 Sensor Coefficients

4221C QUERY COMMANDS

Q1 Sends the ITS-90 coefficients

Sending a Query command ("Q1") asks the 4221C to send the current ITS-90 Coefficients. After the 4221C receives a Query command, it will respond with the seven (7) ITS-90 coefficients, labeled C0 to C6 as follows:

```
C0 = 25.02463
C1 = -5.8320e-04
C2 = +1.108e-05
C3 = 0.0000e+00
C4 = -9.8769e-04
C5 = -3.0704e-04
C6 = 0.0000e+00
```

The 4221C returns to normal operation after C6 is sent. Note: A "?" may be used in place of "Q" in the query command.

The following subroutine will read and display the coefficients for the Sensor1. The coefficients are printed twice, first as a string as read from the 4221C and then converted to a real number.

- Send a "Q1" string with the end of line terminator appended as explained in programming note four (4) of section 3.1.3.
- Use the "bytes at serial port" VI to ascertain the number of bytes the 4221C has sent. This VI is found in Functions/Instrument I/O and Serial.
- Connect the "byte count" terminal of the above terminal to the Serial Number of Bytes read" to the "Serial Port Read" VI found in Functions/Instrument I/O and Serial.
- Add an indicator to the Data Read port of the "Serial Port Read" VI for the reading.
- Enlarge the indicator to display all seven lines received with the prompt ">".

Hint: You can chose not to display the prompt ">" by using the "Split String" VI (In Functions/String) between the Serial Read and the reading indicator. Use ">" as the "Search Char"

3.1.3.4 Programming ITS-90 Sensor Coefficients

4221C PROGRAM COEFFICIENT COMMANDS

P1 programs new ITS-90 coefficients

Sending a PROGRAM COEFFICIENTS command "P1" to the 4221C allows you to program new ITS-90 Coefficients for a sensor.

When the 4221C receives a PROGRAM COEFFICIENTS command, there is a slight delay until the 4221C enters the ENTER PROGRAM COEFFICIENTS mode and is ready to receive the new ITS-90 coefficients.

When the 4221C enters the ENTER PROGRAM COEFFICIENTS mode, it will display "rS-232" on the front panel display. While in this mode, the 4221C will respond with the Status each time it receives a data terminator. See Section 3.1.3.5 for further information on Status.

When the 4221C is in the ENTER PROGRAM COEFFICIENTS mode, any or all of the seven ITS-90 coefficients, C0 to C6, can be sent to the 4221C. The coefficients can be sent in either floating point format (usually C0) or exponential format (C1 to C6).

Floating point format:

e.g.

C0 = 100.0246

There may be an optional number of spaces before the Coefficient Identifier, between the Coefficient Identifier and the equal sign, and between the equal sign and the floating point number.

Exponential format:

e.g.

C1 = -5.8320e-04 or

C1 = -5.8320E-04

There may be an optional number of spaces before the Coefficient Identifier, between the Coefficient Identifier and the equal sign, and between the equal sign and the exponential format number.

There can be no spaces in the exponential format number, i.e. before or after the "e" or "E".

After the new coefficients have been sent to the 4221C, the 4221C can be returned to normal operation with or without programming the new coefficients into non-volatile memory.

To exit the ENTER PROGRAM COEFFICIENTS mode without programming the new coefficients into non-volatile, send "N" with the end of line terminator to the 4221C.

The 4221C will return to normal operation and use the previous coefficients to calculate the temperature.

To exit the ENTER PROGRAM COEFFICIENTS mode with programming the new coefficients into non-volatile memory, send "Y" to the 4221C:

The 4221C will briefly display "donE" and then return to normal operation and use the new coefficients to calculate the temperature.

The following subroutine will program new coefficients into the non-volatile memory.

- Send a "P1" string with the end of line terminator appended as explained in programming note four (4) of section 3.1.3.

- Send "C0 = 25.56123 string with the end of line terminator appended as explained in programming note four (4) of section 3.1.3.
- Send "C1 = -5.8320E-04 string with the end of line terminator appended as explained in programming note four (4) of section 3.1.3.
- Send "C2 = 1.1108E-05 string with the end of line terminator appended as explained in programming note four (4) of section 3.1.3.
- Send "C3 = 0.0000E+00 string with the end of line terminator appended as explained in programming note four (4) of section 3.1.3.
- Send "C4 = -9.8769E-04 string with the end of line terminator appended as explained in programming note four (4) of section 3.1.3.
- Send "C5 = -3.0704E-04 string with the end of line terminator appended as explained in programming note four (4) of section 3.1.3.
- Send "C6 = 0.0000E+00 string with the end of line terminator appended as explained in programming note four (4) of section 3.1.3.
- Send a "Y" string with the end of line terminator appended as explained in programming note four (4) of section 3.1.3.

Note: When using a computer with terminal emulation software, there are no editing commands when entering coefficients. If you make a mistake, simply send a data terminator and re-enter the coefficient.

3.1.3.5 Reading the 4221C Status

Sending a Status command ("S") to the 4221C allows the computer to read the current 4221C Status. The Status command presents the 4221C Status information in a single character.

After the 4221C receives a Status command, it will respond with a character that represents the 4221C Status as follows:

- P - Power-on reset initialization mode.
- F - Front panel busy.
- W - Waiting to enter the ENTER PROGRAM COEFFICIENTS mode.
- B - Busy in the ENTER PROGRAM COEFFICIENTS mode.

- U - Updated reading has not been read.
- N - Reading has been read.

The 4221C Status is "P" following turn on of the 4221C or after a Device Clear command until the display is updated with the first reading.

The 4221C Status is "F" when the front panel is busy calibrating coefficients, calibrating the Analog Output option or changing communication parameters. The Status changes to "F" when the selected position of the internal FUNCTION switch is moved to the "ON" position. When the function is concluded, the Status changes to "N".

The 4221C Status is set to "W" when the 4221C receives a PROGRAM COEFFICIENTS Command and remains "W" until the 4221C enters the ENTER PROGRAM COEFFICIENTS mode.

The 4221C Status is set to "B" when the 4221C enters the ENTER PROGRAM COEFFICIENTS mode. The Status is set to "N" when the 4221C exits the ENTER PROGRAM COEFFICIENTS mode.

NOTE: The Status command is automatic when the 4221C is in the ENTER PROGRAM COEFFICIENTS mode. The 4221C will respond with the Status each time it receives a data terminator until it exits the ENTER PROGRAM COEFFICIENTS mode.

Each time the display is updated, the Status is changed to "U" to indicate that the current reading has been updated since the last time the 4221C was read.

When the current reading is read, the Status is changed to "N", to indicate the reading has been read, and is changed to "U" the next time the display is updated.

The following LavVIEW subroutine uses the Status command to wait until the 4221C updates the displayed reading.

Draw a while loop (Found in Functions/Structures) in the diagram section of a VI.

Put three sequence frames (Found in Functions/Structures) inside the while loop

In the first frame use the serial write VI to send an "S" string with the end of line terminator appended. (Also in this frame put in a 500 ms delay)

In the second frame find the number of bytes at the serial port using the Bytes at Serial Port VI. (Also in this frame put in a 50 ms delay)

In the third frame put the Serial Port Read VI. (Also in this frame put in a 50 ms delay)

Connect the "byte count" terminal of the above terminal to the Serial Number of Bytes read" to the "Serial Port Read" VI found in Functions/Instrument I/O and Serial.

Connect the data out of the Serial Port Read VI to a Match Pattern VI found in Functions/string with the pattern to be match a "U".

Connect the output of the matched pattern and a string "U" to a Not Equal? found in Functions/Comparisons.

- Connect the output of the Not Equal? to the conditional terminal of the aforementioned while loop.
- When the 4221C has updated the condition is met and this routine is complete.

3.1.4 Summary of 4221C RS-232C Commands

FUNCTION	COMMAND	DESCRIPTION
DEVICE CLEAR	^C	Resets the 4221C to the power-on reset state.
CONTINUOUS TRANSMISSION ENABLE / DISABLE (Sec. 3.1.2)	E1	Enables Continuous Transmission..
	E0	Disables Continuous Transmission.
LOCAL (Sec. 3.1.3.2)	L	Returns selection of the measurement scale to the front panel switch.
REMOTE (Sec. 3.1.3.2)	RC RF RO	Changes selection of measurement scale to Celsius, Fahrenheit or Ohms.
PROGRAM COEFFICIENTS (Sec. 3.1.3.4)	P1	Enters 4221C into program mode to allow programming of new ITS-90 sensor coefficients.
QUERY COEFFICIENTS (Sec. 3.1.3.3)	Q1	Provides read-out of current programmed ITS-90 sensor coefficients.
SEND STATUS (Sec. 3.1.3.5)	S	Provides read-out of Status of 4221C.
TRANSMIT READING (Sec. 3.1.3.1)	T	Provides read-out of front panel reading.

ALL COMMANDS ARE UPPER CASE

3.2 IEEE-488/HP-IB/GPIB INTERFACE (OPTION 15)

The IEEE 488 option on the model 4221C can be used two ways:

Talk Only Mode

The 4221C can be used with an IEEE 488 printer with Listen Only capability. In this configuration, readings are sent directly from the 4221C to the printer. No remote commands can be used because there is no controller present. Refer to Section 3.2.1 for further explanation of this mode.

Operation with an IEEE 488 System Controller

The 4221C can be used in an IEEE 488 bus system with a system controller and up to 13 other devices, since the IEEE 488 standard permits up to 15 devices to be configured within one system. In this configuration, the following functions are available:

- (1) Read the current 4221C reading
- (2) Select the measurement scale
- (3) Read current ITS-90 sensor coefficients
- (4) Program new ITS-90 sensor coefficients
- (5) Check status of the 4221C using Serial Poll
- (6) Check status of the 4221C using Status command
- (7) Enable SRQ generation when the 4221C updates the display

Refer to Section 3.2.2 through Section 3.2.2.8 for further explanation of functions available in this mode.

3.2.1 Talk Only Mode

To use the 4221C in the Talk Only mode, connect the 4221C directly to an IEEE 488 printer set for the Listen Only mode.

The sending of readings is controlled by FUNCTION switch S2 position 5 (see Figure 2 & Figure 5).

When the switch is in the "OFF" position, no readings are sent.

When the switch is in the "ON" position, a reading will be sent each time the 4221C updates the display. The measurement scale is selected by the front panel switches. See Section 3.2.2.2 for the reading format. The 4221C will update approximately once per second.

NOTE: While the 4221C is in the the Talk Only mode, the programmed 4221C device address has no effect.

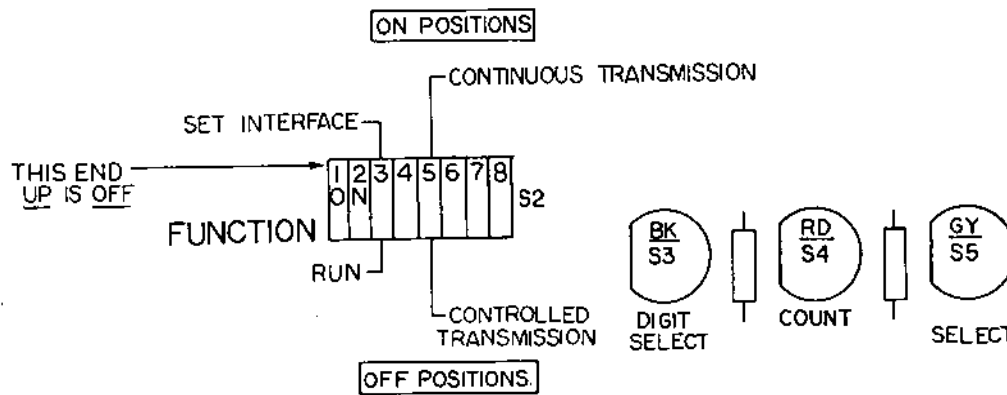

Close up of S2 showing IEEE-488 switches
Figure 5

3.2.2 Operation with an IEEE 488 System Controller

When the 4221C is used with a system controller, the functions listed in the Summary of IEEE 488 COMMANDS are available. In the following descriptions of the IEEE 488 commands, their use is illustrated using example programs written in LabVIEW using an National Instruments IEEE interface card. The following explanations are provided to help use the 4221C with other programming languages and other IEEE 488 interface hardware and software combinations.

Programming Notes

1. The following examples assume that the 4221C device address is programmed to 07. Be sure to use your device address.
2. The 4221C uses data messages to chose "Local" or "Remote" selection of measurement scale and channel. When "Remote" selection is chosen, the front panel switches are ignored. The 4221C does not use the Remote Enable line "REM" or the "Local Lockout" command.
3. The data terminator for bus output to the 4221C and for bus input from the 4221C should be set for Carriage Return <CR> followed by Line Feed with EOI set <LF w/ EOI>.

If you have problems with the controller or the bus hang-ing up, check the data terminators. Also you need to put in delays between input commands and output data of the 4221C. 1/2 to 1 second delay is recommended.

ALL COMMANDS ARE UPPER CASE

4. Two character commands, such as "RC", are two consecutive characters and may not be separated by a space.
5. The following LabVIEW™ routine will program the 4221C to go to remote and read °C:

- Connect a string constant "RC" to the data input of the GPIB Write VI found in Functions/Instrument I/O and GPIB.
 - Connect a string control with the IEEE address of the 4221C to the address terminal of the above VI.
 - Connect an integer constant 3 to the mode terminal of the above VI.
 - Run VI.
6. The following LabVIEW™ routine will read the front panel of the 4221C:
- Connect a string indicator to the data terminal of the GPIB Read VI found in Functions/Instrument I/O and GPIB.
 - Connect a string control with the IEEE address of the 4221C to the address terminal of the above VI.
 - Connect an integer constant 0 to the mode terminal of the above VI.
 - Connect an integer constant 20 to the byte count terminal of the above VI.
 - Run VI.

3.2.2.1 PROGRAMMING THE 4221C DEVICE ADDRESS

Each device connected to the IEEE 488 bus must have a unique address for proper operation. The 4221C can be programmed for any address between 00 and 30. The current device address of the 4221C is displayed during power-on initialization following Lamp Test.

1. Checking current device address

To check the current device address, Locate the FUNCTION switch S2 and move position 3 to the "ON" position, see figure 2 and Figure 5. The display on the 4221C will indicate "Addr", followed by the current device address.

To return the 4221C to normal operation without changing the current device address, Locate the gray COEF SELECT button (figure 2) and press it once. The 4221C will display "rEady". Return switch position 3 to the "OFF" position.

2. Programming a new device address

Locate the FUNCTION switch S2 and move position 3 to the "ON" position. The 4221C will display "Addr" followed by the current device address.

Locate the red "COUNT" button, see figure 2.

Press the "COUNT" button until the desired device address is displayed.

NOTE: "Addr 00" follows "Addr 30".

Locate the gray "COEF SELECT" button.

Press the "COEF SELECT" button to enter the desired device address.

The 4221C will now display "rEAdY".

To program the new device address into the 4221C, move the FUNCTION switch S2 position 1 to the "ON" (Program New Coefficients) position. The 4221C will display "buSY" briefly, then it will display "donE".

The new device address is now programmed. Return the FUNCTION switch S2 positions 1 & 3 to the "OFF" position to return the 4221C to normal operation.

3.2.2.2 Readings from the 4221C

If the 4221C is not in the Read ITS-90 Coefficients mode or the Program ITS-90 Coefficients mode, it will send the current displayed reading when addressed to talk. The 4221C sends the reading as eleven (11) characters followed by the bus data terminator:

[Note the EOI is sent with the <LF>.]

[1] of reading, "+" or "-"

[2] to [9] digits and decimal point of reading decimal point is [5] for Ohms readings decimal point is [6] for temperature readings

[10] space

[11] character for measurement scale ("C", "F" or "O")
<CR><LF w/EOI> bus data terminator

For example,

+035.5928 O<CR><LF w/EOI>

or

+0100.835 C<CR><LF w/EOI>

or

+0213.503 F<CR><LF w/EOI>

The following procedure remotely selects and displays a reading in Celsius, then selects a reading in Fahrenheit, and then returns to Local mode. It uses the procedures shown in Section 3.2.2.

- Send "RC" to the 4221C using the routine described in programming note 5 of 3.2.2.

- Wait 750 ms or more using the Wait function found in Functions/Time and Dialog.
- Read the 4221C using the routine described in programming note 6 of 3.2.2.
- Wait 750 ms or more using the Wait function found in Functions/Time and Dialog.
- Send "RF" to the 4221C using the routine described in programming note 5 of 3.2.2.
- Wait 750 ms or more using the Wait function found in Functions/Time and Dialog.
- Read the 4221C using the routine described in programming note 6 of 3.2.2.
- Wait 250 ms or more using the Wait function found in Functions/Time and Dialog.
- Send "L" to the 4221C using the routine described in programming Note 5 of 3.2.2.

3.2.2.3 Selection of measurement scale

4221C REMOTE / LOCAL COMMANDS

COMMAND

RC	Selects Celsius measurement scale
RF	Selects Fahrenheit measurement scale
RO	Selects Ohms (resistance) measurement scale
L	Returns selection of the measurement scale to the front panel switch.

After power-on reset initialization, the measurement scale of the 4221C is selected by the front panel switch. The measurement scale may be selected by the Remote commands "RC", "RF" or "RO". When a Remote command is received, the front panel switch is ignored until a Local command ("L") returns selection of the measurement scale to the front panel switch.

NOTE: All Remote commands ("RC", "RF" & "RO") are two upper case letters not separated by spaces.

3.2.2.4 READING THE ITS-90 SENSOR COEFFICIENTS

4221C QUERY COMMANDS

Q1 Sends the ITS-90 coefficients

Sending a Query command ("Q1") to the 4221C allows the controller to read the current ITS-90 coefficients. After the 4221C receives a Query command, the next eight (8) times the 4221C is addressed to talk, it will respond with the seven (7) ITS-90 coefficients, labeled C0 to C6 as follows:

```
PROBE 1
C0 = 100.0246
C1 = -5.8320e-04
C2 = +1.1108e-05
C3 = +0.0000e+00
C4 = -9.8769e-04
C5 = -3.0704e-04
C6 = +0.0000e+00
```

The 4221C returns to normal operation after C6 is read.

The next time the 4221C is addressed to talk, it will send the displayed reading.

The following procedure will read and display the coefficients. To read and display the coefficients, send the "Q1" command.

- Create a VI
- On the front panel of the VI place eight (8) string indicators and label the first one "Probe under Test." Label the Second one through the eighth one, "C0" through "C6". The string indicators are found in Controls/String and Table.
- Switch to the diagram.
- On the diagram put a sequence loop with two (2). The sequence frame is found in Functions/Structures.
- In the first frame send "Q1" to the 4221C using the routine described in programming note 5 of 3.2.2.
- Wait 750 ms or more in that frame using the Wait function found in Functions/Time and Dialog.
- Put a For loop in the second frame.
- Put a Wait function in the for loop with the constant 750 connected to it.
- Connect the digit 8 to the N terminal of the for loop. The for loop is found in Functions/Structures.
- Inside the for loop place a sequence loop with 8 frames.
- Also in the for loop read the data as described in programming note 6 of 3.2.2 except use mode 3 and bytes read 30.
- Connect the data terminal of the GPIB Read VI to an input tunnel of the sequence loop. Use mode 0 and a byte count of 30.
 - In the #0 frame place the indicator labeled "Probe Under Test" with the tunnel wired to the indicator.
 - In the #1 frame place the indicator labeled "C0" with the tunnel wired to the indicator.
 - In the #2 frame to the #7 frame place the indicator labeled "C2" to "C7".

- Return to the front panel and run the VI.

3.2.2.5 PROGRAMMING SENSOR COEFFICIENTS FROM THE CONTROLLER

4221C PROGRAM COEFFICIENT COMMAND

COMMAND

P1 Programs new ITS-90 coefficients for the sensor

Sending a PROGRAM COEFFICIENTS command ("P1") to the 4221C allows the controller to program new ITS-90 Coefficients for the sensor.

When the 4221C receives a PROGRAM COEFFICIENTS command, there is a slight delay until the 4221C enters the ENTER PROGRAM COEFFICIENTS mode and is ready to receive the new ITS-90 coefficients. While the 4221C is waiting, the Serial Poll response will be 2, (bit 2 set ON), and if the 4221C is addressed to talk, it will respond with status character of "W". (See Sec 3.2.2.8)

When the 4221C enters the ENTER PROGRAM COEFFICIENTS mode, it will display "IEEE488" on the front panel display, the Serial Poll response will be 4 (bit 4 set ON) and, if the 4221C is addressed to talk, it will respond with status of character of "B".

To keep from sending coefficients to the 4221C before it enters the ENTER PROGRAM COEFFICIENTS mode, Serial Poll the 4221C until the Serial Response is 4 (bit 4 set ON) or until the status character is "B". See the following Program_Constants procedure example.

When the 4221C is in the ENTER PROGRAM COEFFICIENTS mode, the following can be programmed:

Any or all of the ITS-90 coefficients, C0 to C6.

The sensor serial number.

The Date - the Calibration date or the Due date.

The coefficients can be sent in either floating point format or exponential format.

Floating point format:

Typically C0 is programmed in this format. e.g.

C0 = 25.65123

There may be an optional number of spaces before the Coefficient Identifier, between the Coefficient Identifier and the equal sign, and between the equal sign and the floating point number.

Exponential Format:

Typically C1 through C6 are programmed in this format. e.g.

C1 = -5.8320e-04 or
C1 = -5.8320E-04

C2 = 1.1108e-05 or
C2 = +1.1108e-05

There may be an optional number of spaces before the Coefficient Identifier, between the Coefficient Identifier and the equal sign, and between the equal sign and the exponential format number.

There can be no spaces in the exponential format number, i.e. before or after the "e" or "E".

The plus sign in front of positive coefficients is optional.

Serial Number Format:

The constant identifier for the serial number is "S#", "SN", or "S". The serial number is limited to seven (7) digits. If fewer than seven digits are sent, zeros are added to the end, to make seven digits.

S# = 1234567 or
SN = 1234567 or
S = 1234567

S# = 123 will be programmed as S# = 1230000

Date Format:

The constant identifier for the date is "DA" or "D". the date consists of six (6) digits followed by "C" for "Calibration Date" or "D" for "Due Date". The date may be separated into groups of two (2) by spaces or any other non-numeric character (e.g. "-"). The "C" or "D" may be separated from the last date digit by an optional number of spaces. If a "C" or "D" is not sent, a "D" will be programmed.

D = 100590C or
D = 10-05-90 C

After the new coefficients have been sent, the 4221C can be returned to normal operation with or without programming the new coefficients into the non-volatile RAM.

To exit the ENTER PROGRAM COEFFICIENTS mode without programming the new coefficients into non-volatile RAM, send "N" to the 4221C:

The 4221C will return to normal operation and use the previous coefficients to calculate the temperature.

To exit the ENTER PROGRAM COEFFICIENTS mode with programming the new coefficients into non-volatile RAM, send "Y" to the 4221C:

The 4221C will briefly display "donE" and then return to normal operation and use the new coefficients to calculate the temperature.

The following procedure will program new coefficients into the non-volatile RAM.

- Create a VI
- On the front panel of the VI place eight (8) string controls and label them "C0" through "C6". The string controls are found in Controls/String and Table.
- Write in each string control box desired data as formatted above.
- Switch to the diagram.
- On the diagram put a sequence loop with 11 frames. The sequence frame is found in Functions/Structures.
- In frame #0 send "P1" to the 4221C using the routine described in programming note 5 of 3.2.2.
- Wait 750 ms or more in that frame using the Wait function found in Functions/Time and Dialog.
- Put a while loop in frame #1. The sequence frame is found in Functions/Structures.
- In the While loop, put a (Serial) Poll VI, found in Function/instrument I/O/ and GPIB addressed to the 4221C.
- Connect the Serial poll byte to one input of a not equal comparison with a numeric constant of 4 to the other terminal.
- Connect the output of the not equal comparison to the conditional terminal of the While loop.
- In the #3 frame place the connect the control for "C0" to the data input of a GPIB write VI wired to mode 3. Place a 500 ms delay in this frame.
- In the #4 frame place the connect the control for "C1" to the data input of a GPIB write VI wired to mode 3. Place a 500 ms delay in this frame.

Bit 3 (8)	Not Used
Bit 2 (4)	<p>ON = The 4221C is in the ENTER PROGRAM COEFFICIENTS mode and is ready to receive new ITS-90 coefficients. (See Sec. 3.2.2.5)</p> <p>OFF = Reset to OFF when the 4221C leaves The ENTER PROGRAM COEFFICIENTS mode.</p>
Bit 1 (2)	<p>ON = The 4221C is waiting to enter the ENTER PROGRAM COEFFICIENTS mode. This bit is set on when a PROGRAM COEFFICIENTS Command is received by the 4221C. (See Sec. 3.2.2.5)</p> <p>OFF = Reset to OFF when the 4221C enters The ENTER PROGRAM COEFFICIENTS mode.</p>
Bit 0 (1)	<p>ON = Set ON when the 4221C reading is updated.</p> <p>OFF = Reset to OFF the first time the updated 4221C reading is read by the controller.</p>

The following procedure will wait until the 4221C updates the displayed reading. It can be used to wait until a new measurement scale displayed (See Sec 3.2.2.3) or to read consecutive updates from the 4221C.

NOTE: The serial poll is the preferred way to wait for an update rather than using the status command.

- In the diagram for a VI put a While loop.
- In the while loop Put a (Serial) Poll VI, found in Function/instrument I/O and GPIB addressed to the 4221C.
- Connect the Serial poll byte to one input of an "and" found in Functions/Boolean with the other input connected to a constant "1".
- Connect the Serial poll byte also to one input of a not equal function and the above "and" connected to the other input.
- Connect the output of the not equal comparison to the conditional terminal of the While loop.
- When the 4221C is updated the condition for while loop will be met and the program will proceed.

3.2.2.7 SRQ GENERATION ON 4221C UPDATE

The 4221C can be programmed to generate a Service Request (SRQ) each time the 4221C updates the display, approximately once per second.

The controller must be programmed to recognize the SRQ and to then serial poll each device on the IEEE 488 bus to determine which device requested service. This allows the controller to read the 4221C each time the display is updated and perform other operations while the 4221C is between update cycles instead of continually monitoring the Serial Poll response of the 4221C. The 4221C will request service only when a new reading is ready.

Operation in this mode is selected by the SERVICE REQUEST DISABLE/ENABLE command. After power-on reset initialization, the SERVICE REQUEST is disabled. It is enabled by the command "E1" and disabled by the command "E0".

When this mode is enabled, the 4221C will assert the SRQ line to request service each time it updates the display (i.e. completes a measurement cycle). It will release the SRQ line the first time the 4221C is serial polled.

NOTE: When this mode is disabled (Command "E0"), Bits 5 and 6 will always be OFF and the 4221C will not request service via the SRQ line when it updates a reading.

Whether this mode is enabled (command "E1") or disabled (command "E0") has no effect on Bit 0. Bit 0 is always set ON with each update and set OFF each time the 4221C is read.

When this mode is enabled, the first response to a serial poll after the 4221C has requested service will be the decimal value 97 (Bits 6,5 and 0 set ON).

Bit 6 and 5 both indicate that the 4221C has requested service.

Bit 0 indicates that latest reading has not been read by the controller.

Bit 6 is turned off by the First Serial Poll.

Bit 5 and Bit 0 (decimal number 65) are turned off the First time the 4221C reading is read.

The following procedure will wait until the 4221C requests service before proceeding. It can be used to wait until a new measurement scale or measurement channel is displayed (See Sec 3.2.2.3) or to read consecutive updates from the 4221C.

NOTE: The service request (SRQ) is used to tell the controller that the 4221C has updated its reading.

- Send "E1" to the 4221C using the routine described in programming note 5 of 3.2.2.
- In the diagram for a VI put a While loop.
- In the while loop Put a SRQ test VI, found in Function/instrument I/O and GPIB 488.2 with the bus number wired to the input of the VI.
- Connect the output of the SRQ test VI the input of a "not" function, found in Functions/boolean, with the output connected to the conditional terminal of the While loop.
- When the 4221C request service the condition for while loop will be met and the program will proceed.
- NOTE: You must use the serial poll routine found in 3.2.2.6 in order to turn off SRQ.

3.2.2.8 READING THE 4221C STATUS

Sending a Status command ("S") to the 4221C allows the controller to read the current 4221C Status. The Status command presents the same 4221C Status information as the Serial Poll Response byte (except there is no Service Request information) in a single character instead of the eight-bit format of the Serial Poll response.

After the 4221C receives a Status command, the next time it is addressed to talk it will respond with a character that represents the 4221C Status as follows:

- P - Power-on reset initialization mode.
- F - Front panel busy.
- W - Waiting to enter the ENTER PROGRAM COEFFICIENTS mode.
- B - Busy in the ENTER PROGRAM COEFFICIENTS mode.
- U - Updated reading has not been read.
- N - Reading has been read.

The 4221C status is "P" following turn on of the 4221C or after a Device Clear command until the display is updated with the first reading.

The 4221C Status is "F" when the front panel is busy calibrating coefficients, calibrating the Analog Output option or changing the device IEEE address. The Status changes to "F" when the selected position of the internal FUNCTION switch is moved to the "ON" position. When the function is concluded, the status changes to "N".

The 4221C status is set to "W" when the 4221C receives a PROGRAM COEFFICIENTS Command and remains "W" until the 4221C enters the ENTER PROGRAM COEFFICIENTS mode.

The 4221C status set to "B" when the 4221C enters the ENTER PROGRAM COEFFICIENTS mode. The Status is set to "N" when the 4221C exits the ENTER PROGRAM COEFFICIENTS mode.

NOTE: The Status command is automatic when the 4221C Status is "W" or "B", that is when the 4221C is waiting to enter or is in the ENTER PROGRAM COEFFICIENTS mode.

The 4221C will respond with the Status each time it is commanded to talk until it exits the ENTER PROGRAM COEFFICIENTS mode.

Each time the display is updated, the Status is changed to "U" to indicate that the current reading has been updated since the last time the 4221C was read.

When the current reading is read, the Status is changed to "N", to indicate the reading has been read, and is changed to "U" the next time the display is updated.

NOTE: The use of the SRQ test is preferred to using the Status command. The SRQ test examines the IEEE488 command lines without interrupting the 4221C. The status command interrupts the 4221C.

THIS PAGE INTENTIONALLY BLANK

3.2.3 SUMMARY of 4221C IEEE-488 COMMANDS

3.2.3.1 Summary of 4221C Device Specific IEEE-488 Commands

FUNCTION	COMMAND	DESCRIPTION
SERVICE REQUEST	E0	Disables Service Request
DISABLE / ENABLE (Sec. 3.2.2.7)	E1	Generation on Update. Enables Service Request Generation on Update.
LOCAL (Sec. 3.2.2.3)	L	Returns selection of the measurement scale to the front panel switch.
REMOTE (Sec. 3.2.2.3)	RC RF RO	Changes selection of measurement scale to Celsius, Fahrenheit or Ohms.
	R1	Read front Panel Measurement
PROGRAM COEFFICIENTS (Sec. 3.2.2.5)	P1	Enters 4221C into program mode to allow programming of new ITS-90 sensor coefficients.
QUERY COEFFICIENTS (Sec. 3.2.2.4)	Q1	Provides readout of current programmed ITS-90 sensor coefficients.
STATUS (Sec. 3.2.2.8)	S	Provides a character representing the Status of the 4221C.

ALL COMMANDS ARE UPPER CASE

3.2.3.2 Summary of 4221C Multiline IEEE-488 Commands

The following general bus commands are supported:

- IFC - Interface Clear
The 4221C enters the talk and listen idle states with the Service Request on Update disabled.

- DCL - Device Clear (Device Clear Universal)
The 4221C returns to the power up state.
 - A. The display will perform a Lamp Test, all 8's, followed by a display of the IEEE address.
 - B. Status character is set to "P".
 - C. Serial Poll Response byte set to 80H (Bit 7 = ON)
 - D. Service Request on Update disabled.
 - E. Measurement scale returned to Local (Setting of Front Panel Switch)

- SDC - Selective Device Clear (Device Clear Addressed)
The 4221C returns to the power up state.
(Same as DCL)

- SPE - Serial Poll Enable
- SPD - Serial Poll Disable A serial polling sequence is used to determine the current operating status of the 4221C. Normally the 4221C is polled along with the other devices on the bus to determine which device requested service. The 4221C responds to the serial polling sequence with a serial Poll Response byte which identifies the current status. Refer to Paragraph 3.2.6 for more information on the Response byte format.

The following general bus commands are NOT supported:

- REN - Remote Enable
This command is not used. Remote selection of the measurement scale is available using the "R" command.

- GTL - Go To Local
This command is not used. Control of the measurement scale is returned to the front panel switch by the "L" (Local) command.

- LLO - Local Lockout
This command is not used. The front panel switch is "Locked Out" after a "R" (Remote) command until a "L" (LOCAL) command.

3.2.3.3 4221C IEEE-488 Interface Function Subsets

The 4221C implements the following subsets of the Interface Functions:

- SH1 - Source Handshake
Full Capability
- AH1 - Acceptor Handshake
Full Capability
- T5 - Talker
Basic Talker, Serial Poll,
Talk Only Mode, Unaddresses if MLA
- TE0 - Extended Talker
No Capability
- L4 - Listener
Basic Listener, Unaddresses if MTA
- LE0 - Extended Listener
No Capability
- SR1 - Service Request
Full Capability
- RL0 - Remote Local
No Capability
(The 4221C uses messages for remote operation)
- PP0 - Parallel Poll
No Capability
- DC1 - Device Clear
Full Capability
- DT0 - Device Trigger
No Capability
- C0 - Controller
No Capability
- E2 - Driver Electronics
Tri State
(May be jumpered for E1 [Open Collector] for use
with Parallel Poll)

3.3 ANALOG OUTPUT (Option 08)

The 4221C Series Analog output option uses a 12 bit DAC with a switched reference to give an output of -4.095 volts to +4.095 volts with 1 mV resolution. The analog output is controlled by three parameters:

- Analog Output Scale
- Analog Output Resolution
- Analog Output Zero offset

These three parameters are stored in non-volatile Memory and can be programmed using the 4221C internal switches or using the interface, either IEEE-488 or RS-232, if installed.

The value of the analog output is the difference between the value of the sensor, in the selected Analog Output scale, and the Analog Output Zero offset, multiplied by the Analog Output Resolution. Note that the analog output scale is independent of the displayed scale.

For example, assume the displayed sensor is at ??.???, Ohms, 100.00 C and 212.00 F.

With Analog Output Scale = F
Analog Output Resolution = 1mV / 0.1
Analog Output Zero offset = +000.000
The analog output would be:

$$(212.00 - 0.000) * 1\text{mV} / 0.1 = 2120 \text{ mV} = 2.120 \text{ V}$$

With Analog Output Scale = F
Analog Output Resolution = 1mV / 0.1
Analog Output Zero offset = +200.000
The analog output would be:

$$(212.00 - 200.000) * 1\text{mV} / 0.1 = 120 \text{ mV} = 0.120 \text{ V}$$

With Analog Output Scale = F
Analog Output Resolution = 1mV / 0.01
Analog Output Zero offset = +200.000
The analog output would be:

$$(212.00 - 200.000) * 1\text{mV} / 0.01 = 1200 \text{ mV} = 1.200 \text{ V}$$

3.3.1 ANALOG OUTPUT PARAMETERS

Analog Output Scale

The analog output can represent the resistance of the sensor in Ohms or the temperature of the sensor in Celsius or Fahrenheit. The scale of the analog output is independent of the displayed scale as selected by the front panel switch or remotely by either the IEEE-488 or RS-232 interface.

Analog Output Resolution

The resolution giving a 1 millivolt step can be selected from the following:

- 1 mV / 1.0 C, F or Ohm
- 1 mV / 0.1 C, F or Ohm
- 1 mV / 0.01 C, F or Ohm
- 1 mV / 0.001 C, F or Ohm

Analog Output Zero offset

The Zero offset can be from -999.999 to +999.999.

3.3.2 CHECKING OR PROGRAMMING THE ANALOG OUTPUT PARAMETERS

1. Refer to Figure 2 and Figure 6 to Locate the programming switches.

Move position 6 of the FUNCTION Switch S2 to the "ON" position to put the 4221C in the SET ANALOG PARAMETERS mode.

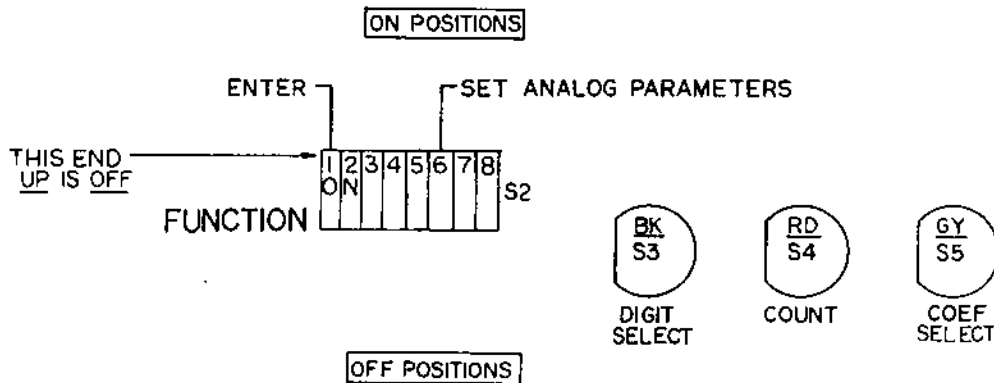

Close up of S2 showing Analog Output Programming Switches
Figure 6

2. The 4221C will display "Aout" briefly, followed by the current analog output scale:

- "SCALE C" for C
- "SCALE F" for F
- "SCALE O" for Ohms

To change the analog output scale, press the red "COUNT" pushbutton until the desired scale is displayed.

Press the gray "COEF SELECT" pushbutton to continue.

3. The 4221C will then display the current analog output resolution:

```
"r  1.0" for 1 mV / 1.0  C, F or Ohm
"r  0.1" for 1 mV / 0.1  C, F or Ohm
"r  0.01" for 1 mV / 0.01 C, F or Ohm
"r  0.001" for 1 mV / 0.001 C, F or Ohm
```

To change the analog output resolution, press the red "COUNT" pushbutton until the desired resolution is displayed.

Press the gray "COEF SELECT" pushbutton to continue.

4. The 4221C will then display the current analog output Zero offset. 'P' is displayed for the '+' sign. To change the Zero offset:

Press the black "DIGIT SELECT" pushbutton to select the desired digit to change.

Press the red "COUNT" pushbutton to change the value of the digit.

When the desired Zero offset is displayed, press the Gray "COEF SELECT" pushbutton to continue.

5. The 4221C will then display "rEAdY".

To return the 4221C to normal operation without changing the previous Analog Output Parameters, return position 3 of the FUNCTION switch to the "OFF" position.

To program the 4221C with the new Analog Output Parameters, move the FUNCTION switch S2 position 1 to the "ON" (Program New Coefficients) position.

The 4221C will display "donE" after the new parameters are programmed. Return the FUNCTION switch S2 positions 1 & 3 to the "OFF" position to return the 4221C to normal operation.

3.3.3 ANALOG OUTPUT INTERFACE COMMANDS

If an interface option is installed, either the IEEE-488 or the RS-232 interface, commands are available to set the three Analog Output Parameters and to read the current Analog Output Parameters.

Analog Output Scale Commands

COMMAND

WC	Selects Celsius
WF	Selects Fahrenheit
WO	Selects Ohms

The scale of the analog output is independent of the displayed scale as selected by the front panel switch or remotely by either the IEEE-488 or RS-232 interface.

Analog Output Resolution

COMMAND

WO	Selects 1 mV / 1.0	C, F or Ohm
W1	Selects 1 mV / 0.1	C, F or Ohm
W2	Selects 1 mV / 0.01	C, F or Ohm
W3	Selects 1 mV / 0.001	C, F or Ohm

Analog Output Zero offset

COMMAND

X	Sets Zero offset to current value of sensor in Analog Output Scale.
---	---

When an X command is received, the Zero offset will be set to the current value of the sensor in the current Analog Output Scale. This will cause the Analog Output to go to zero.

Z = szzz.zzz	Sets Zero offset to szzz.zzz s = optional sign + or - z = digit 0-9
--------------	---

The Z = szzz.zzz command is used to set the Analog Output Zero offset to a desired number. The format of the number is not critical and can be scientific notation. For example,

Z = 100.000	will set the Zero offset to 100.000
Z = 1e ²	will set the Zero offset to 100.000
Z = -50.123	will set the Zero offset to -50.123

3.3.4 READING THE CURRENTLY PROGRAMMED ANALOG OUTPUT PARAMETERS VIA INTERFACE

If the 4221C is not in the Read ITS-90 Coefficients mode or the Program ITS-90 Coefficients mode, the current Analog Output Parameters may be read using the 'A' command. The parameters are sent as shown below:

COMMAND A Sets 4221C to respond with current Analog Output Parameters

RESPONSE R=xy z=szzz.zzz

Response Format:

x = Analog Output Scale

C = Celsius

F = Fahrenheit

O = Ohms

y = Analog Output Resolution

0 = 1 mV / 1.0 C, F or Ohm

1 = 1 mV / 0.1 C, F or Ohm

2 = 1 mV / 0.01 C, F or Ohm

3 = 1 mV / 0.001 C, F or Ohm

szzz.zzz = Analog Output Zero offset

s = sign, + or -

zzz.zzz = number, 000.000 to 999.999

3.3.5 EXAMPLE of PROGRAMMING VIA RS-232C INTERFACE

The following VI written in LabVIEW™ will display the current Analog Output Parameters, both as the string as read from the 4221C and as characters for the Scale and Resolution and as a real number for the Zero Offset.

- Send an "A" string with the end of line terminator appended as explained in programming note four (4) of section 3.1.3.
- Use the "bytes at serial port" VI to ascertain the number of bytes the 4221C has sent. This VI is found in Functions/Instrument I/O and Serial.
- Connect the "byte count" terminal of the above terminal to the "Serial Number of Bytes read" to the "Serial Port Read" VI found in Functions/Instrument I/O and Serial.
- Add an indicator to the Data Read port of the "Serial Port Read" VI for the reading of the Response.
- See above for meaning of the response.
- Enlarge the indicator to display all the lines received with the prompt ">".
- Hint: You can chose not to display the prompt ">" by using the "Split String" VI (In Functions/String) between the Serial Read and the reading indicator. Use ">" as the "Search Char"

The following VI written in LabVIEW™ will set the Analog Output Scale to Celsius, the Analog Output Resolution to 0.01 C / millivolt and the Analog Output Zero Offset to 100.000.

- Send the 4221C a string formatted as "WC W2 Z = 100.0".
- Append the end of line terminator appended as explained in programming note four (4) of section 3.1.3.
- Run the VI.

3.3.6 EXAMPLE of PROGRAMMING VIA IEEE-488 INTERFACE

The following VI written in LabVIEW™ for the GPIB interface will display the current Analog Output Parameters, both as the string as read from the 4221C and as characters for the Scale and Resolution and as a real number for the Zero Offset.

- Send "A" to the 4221C using the routine described in programming note 5 of 3.2.2.
- Wait 750 ms or more using the Wait function found in Functions/Time and Dialog.
- Read the 4221C using the routine described in programming note 6 of 3.2.2.
- Note: Stretch the string indicator to read all the parameters.
- Run the VI.

The following VI written in LabVIEW™ will set the Analog Output Scale to Celsius, the Analog Output Resolution to 0.01 C / millivolt and the Analog Output Zero Offset to 100.000.

- Connect a string constant "WC W2 Z = 100.0" to the data input of the GPIB Write VI found in Functions/Instrument I/O and GPIB.
- Connect a string control with the IEEE address of the 4221C to the address terminal of the above VI.
- Connect an integer constant 3 to the mode terminal of the above VI.
- Run the VI.

4. CALIBRATION PROCEDURES

The Model 4221C Temperature Monitor is calibrated in accordance with the International Temperature Scale of 1990 (ITS-90). The 4221C conforms to the R vs T tables generated by formulas from the NIST Technical Note 1265 within the range of -218 to +660°C.

The 4221C is burned-in and factory calibrated prior to shipment. It is designed to remain in calibration for a minimum of before a recalibration check is required.

There is only one calibration adjustment. This adjustment, if necessary, is performed during the Calibration of Ohmmeter Section (4.1) and is normally made at Full Scale.

4.1 CALIBRATION of OHMMETER SECTION

Instrument accuracy, as an Ohmmeter, is +3 PPM +0.0003 ohms. To verify calibration and linearity, readings should be made at 2 or 3 points, such as:

INSTRUMENT	CALIBRATION STANDARD	
	ACCURACY	ACCURACY (3:1 RATIO)*
10 ohms	+0.0003 ohms (30 PPM)	+0.0001 ohms (10 PPM)
50 ohms	+0.0004 ohms (9 PPM)	+0.00015 ohms (3 PPM)
100 ohms	+0.0006 ohms (6 PPM)	+0.0002 ohms (2 PPM)

The best technique to achieve this accuracy is to use stable, low temperature coefficient resistors which are maintained in a temperature controlled enclosure and whose values are precisely known.

Such resistors as Tinsley/Wilkens AC/DC resistors mounted in a table top constant temperature enclosure would be a suitable standard.

Be sure to use 4 wire connection. The use of ordinary copper hookup wire is acceptable. However, to insure homogeneity and thus minimize thermal emf's, the wires should be cut successively from the same length of wire. Length of the wires is not important and they need not be of equal lengths.

*MIL-STD-45662A requires a 4:1 Ratio

After connections are made, the 4221C should be closed up and allowed to "soak" for a minimum of 2 hours.

4.1.1 FULL SCALE CALIBRATION ADJUSTMENT

R101 is the only analog adjustment and is for full scale or for the highest resistance to which the instrument is used. A clockwise rotation increases the reading.

When making an adjustment, the top cover should be opened only as long as necessary. After closing the top cover, wait 15 minutes before making a new reading.

If there is a problem at low end calibration, i.e. 10 ohms, there is a "Zero" adjustment available. See next paragraph.

4.1.2 ZERO OFFSET CORRECTION

This correction is initially made at the factory and should not normally need to be made again, unless U2 is replaced.

MODEL 4221C _____ S/N _____

ZERO OFFSET CORRECTION, _____ OHMS

4.1.2.1 VERIFYING CURRENT ZERO OFFSET CORRECTIONS.

First, verify that the factory measured offset corrections are present in memory.

Refer to Figure 7 and, if necessary, to general programming procedures in paragraph 2.3.3. After SW #2 of FUNCTION switch S2 is pushed to ON. Operate SW #4 of S2 to ON. You are now in the Program mode.

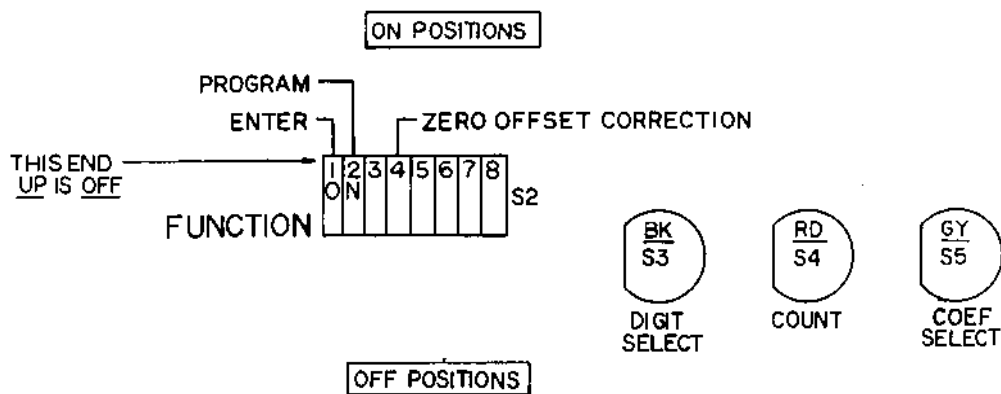

Close up of S2 showing Zero offset
Correction Programming Switches
Figure 7

Operate COEF SELECT pushbutton until menu #9 is displayed by the extreme right hand digit.

0 0 0 0 0 0 0 9

This display indicates the Zero offset Correction that is currently in memory. Compare this reading to the "Zero offset Correction: listed in 4.1.2. If it agrees, but there is good reason to believe that it is not correct, move to 4.1.2.2. If it does not agree, adjust it in accordance with paragraph 4.1.2.3. Note that the display gives an extra Decade of Resolution over what is normally displayed. This menu will not come up if SW #4 of S2 is not ON.

4.1.2.2 DETERMINING NEW ZERO ofFSET CORRECTIONS.

If for some reason the offset amount does not appear to be correct, a new offset can be determined. The preferred method is to use a 1 ohm (or alternately 10 ohms) standard resistor, measured to an accuracy of +10ppm. Adjust the Zero offset until the instrument reads the 1 ohm (or 10 ohm) Resistor exactly. See Paragraph 4.1.2.3 for programming instructions. Allow 2 to 3 hours of soak time between adjustments. Record new offset corrections with polarity.

An alternate, but less accurate method (by 1 to 2 LSD) is to short the four (4) input terminals together, using shorting links. Terminals are on 3/4" centers. Adjust the Zero offset until the instrument reads 0.00000. See Paragraph 4.1.2.3 for programming instructions. The instrument has a "live" zero and will read negative numbers. Allow a two (2) hour warmup when using this method. Record new offset corrections with polarity.

4.1.2.3 PROGRAMMING NEW ZERO OFFSET CORRECTIONS INTO MEMORY

For assistance, refer to Paragraph 2.3.3 for general programming procedures. Operate SW #2 & 4 of S2 to ON. Operate COEF SELECT pushbutton until Menu #9 is displayed by the extreme right hand digit.

□ □ . □ □ □ □ □ □

This display indicates the ZERO OFFSET CORRECTION that is currently in memory.

Use the COUNT and DIGIT SELECT pushbuttons to change the display to read the desired numbers. Note that the display gives an extra decade of resolution than what is normally displayed. This menu will not come up if SW #4 of S2 is not ON.

Operate COEF SELECT until the display reads READY.

Operate SW #1 of S2 to ON. Selected values are now being entered into memory.

When display reads DONE, operate SW #1,2 & 4 of S2 to OFF. Instrument will commence reading sensor input.

Full scale calibration should be done after any adjustment to ZERO OFFSET CORRECTION.

4.2 VERIFYING RESISTANCE TO TEMPERATURE CALCULATIONS

This section of the calibration procedure verifies the microprocessor controlled digital math function.

This 4221C function is not subject to aging or temperature drift, and has no adjustments. It will only calculate erroneously if there is a component failure. Therefore frequent verification is not necessary, if at all.

4.2.1 PROCEDURE OUTLINE

To verify the 4221C math calculations you will need:

- A) A Decade Resistance Box with 0.0001 ohm resolution, such as:

Electro Scientific Industries Model RS 925
Resistance Standard

Accuracy is not important in this application.

- B) Four wire leadwire.
- C) An RvsT Table for a Platinum RTD calculated in accordance with ITS-90
or
- D) Use the Sample Math Test listed in this section.

The 4221C will be used to read the resistance of the Decade Resistance Box. The instrument calculated temperature is then compared to the temperature obtained from the RvsT table.

If you are using the R vs T table for your sensor, this will also check the programming of the coefficients.

4.2.2 PROCEDURE

- 4.2.2.1 Program the 4221C with the proper coefficients for the RvsT table that you are using.
- 4.2.2.2 Disconnect the sensor and connect the Decade Resistance box.
- 4.2.2.3 Switch the 4221C to OHMS and adjust the Decade Resistance Box until the instrument reads the exact value in Ohms for the first selected temperature.
- 4.2.2.4 Operate the "UNITS" switch to F and C. Compare instrument calculated temperature to the R vs T table. It should agree within $\pm 0.001^{\circ}\text{C}$ or 0.002°F .
- 4.2.2.5 Repeat for additional points, as desired.
- 4.2.2.6 When the test is concluded, disconnect the Resistance Decade Box and reconnect sensor. Observe correct terminal markings.

NOTE

If the coefficients were changed for this test, be sure to reprogram the 4221C with the coefficients for the sensor you are currently using.

Close up case and allow for the proper warm-up period.

4.3 SPOT CHECK of SYSTEM ACCURACY

A simple, but effective system calibration check can be performed using an Ice Bath.

Periodically immerse the system RTD sensor in a distilled water Ice Bath.

The distilled water Ice Bath may not read exactly 0.000°C , but the readings should be consistent from test to test.

While this spot check will not verify full range system accuracy, the constancy of the Ice Bath readings is a useful indicator of system stability.

4221C MATH TEST

TOLERANCE = $\pm 0.001^{\circ}\text{C}$ or 0.002°F

ITS-90

25.5 ohm SPRT Sub Range -189 to +660 $^{\circ}\text{C}$

#0 (Rtp) = 25.56194 #1 (a7) = 2-6.5820 #2 (b7) = 2P8.7673

#3 (c7) = 2-2.6393 #4 (a4) = 5-5.1730 #5 (b4) = 6P1.3108

#6 (c1) = 0P0.0000

OHMS	$^{\circ}\text{C}$	$^{\circ}\text{F}$	OHMS	$^{\circ}\text{C}$	$^{\circ}\text{F}$
5.4461	___-190.00,	___-310.000	45.0593	___+200.000,	___+392.000
9.8497	___-150.000,	___-238.000	54.7722	___ 300.000,	___ 572.000
15.1982	___-100.000,	___-148.000	64.1627	___ 400.000,	___ 752.000
20.4239	___ -50.000,	___ -58.000	73.0427	___ 500.000,	___ 932.000
25.5609	___ 0.000,	___ +32.000	81.2907	___ 600.000,	___1112.000
35.2494	___+100.000,	___+212.000	85.9120	___ 660.000,	___1220.000

5. THEORY of OPERATION

The instrument consists of three basic sections:

1. Analog section
2. Analog to Digital section
3. Digital section

ANALOG SECTION

The purpose of the analog section is to convert the resistance of the platinum RTD into voltages that can be measured by the Analog to Digital Conversion section. This is done by using a current generator to send a nominal 1 mA current through the RTD and an internal reference resistor connected in series (See Fig.8). The voltage across the RTD ($e_1 - e_2$) is equal to the current (I) times the resistance (R_{RTD}), i.e.

$$(e_1 - e_2) = I R_{RTD}$$

$$\text{Similarly, } (e_3 - e_4) = I R_{REF}$$

Since the RTD and the reference resistor are connected in series, the ratio of the voltages will be equal to the ratio of the resistances, i.e.

$$R_{RATIO} = \frac{(e_1 - e_2)}{(e_3 - e_4)} = \frac{I R_{RTD}}{I R_{REF}} = \frac{R_{RTD}}{R_{REF}}$$

The reference resistor is adjusted to exactly 100 Ohms, so that:

$$R_{RATIO} = \frac{R_{RTD}}{100 \text{ Ohms}}$$

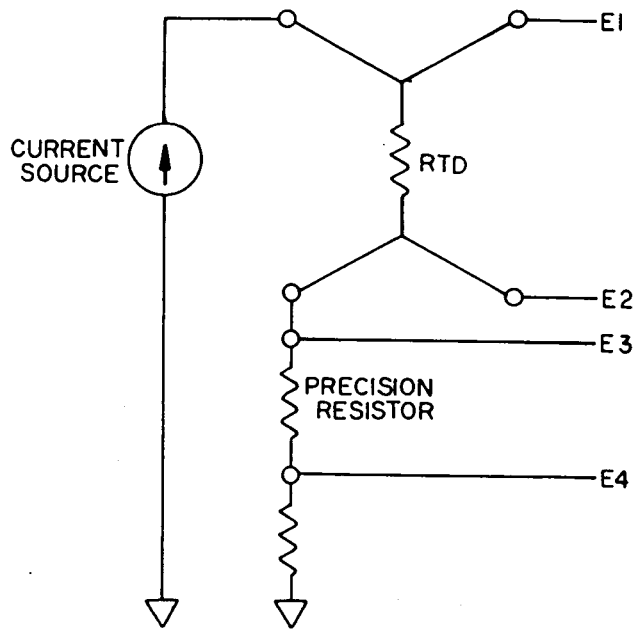

Ratio Measuring Technique
Figure 8

ANALOG TO DIGITAL CONVERTER SECTION

The purpose of the Analog to Digital Converter section is to transform the analog inputs (e1, e2, e3, and e4) into digital numbers that the Digital section uses to compute the resistance and temperature of the RTD.

Each resistance measurement cycle consists of four conversions, one for each input voltage. Since the computation of the resistance depends on the differences of voltages ($e1 - e2$ and $e3 - e4$), any zero-offset errors in the A-to-D Converter will be canceled by the subtraction, if the zero-offset does not change significantly during a measurement cycle. Since the computation of the resistance is the ratio of two voltages ($[e1 - e2]/[e3 - e4]$) a small change in the scale factor of the A-to-D Converter will be divided out, if it does not change significantly during a measurement cycle.

The basic accuracy of the instrument is determined by the linearity of the A-to-D Converter and the accuracy and stability of the reference resistor. The dual slope integration technique is used for its excellent linearity and inherent noise rejection. The reference resistor has a low temperature coefficient, less than 1 PPM/°C.

DIGITAL SECTION

The Digital section controls the operation of the A-to-D Converter, computes the resistance and temperature of the RTD, displays the selected measurement scale on the front panel, and allows the user to enter and store the constants for a particular RTD.

At the end of each measurement cycle, the Digital section computes the resistance of the RTD. This new reading is then compared to the previous average. If the difference is less than 1 milliohm, then the new resistance is averaged with the previous readings, up to a maximum of nine. This reduces random noise for a steady reading by a factor of 10. If the difference is greater than 1 milliohm, then up to two successive readings are ignored. This prevents short spikes of external noise from affecting the display. When three successive readings differ, the latest resistance is used. This allows the instrument to follow a quickly changing probe.

The temperature is then computed using formulas in accordance with ITS-90, and the constants of the RTD which have been programmed into the 4221C. The instrument then displays the new reading in the selected measurement scale.

INTENTIONALLY BLANK

6. TROUBLESHOOTING

The following troubleshooting hints will help you to locate most user associated problems. Please contact the factory if your problem cannot be solved using this guide.

PROBLEM

Instrument was working OK, but suddenly started reading EEEEEEE or extremely large or small measurements or erratic unstable readings.

POSSIBLE CAUSE

Open sensor, loose sensor leads.

PROBLEM

Display reading drifts down.

POSSIBLE CAUSE

Sensor high potential (+P) lead is open.

PROBLEM

Display reading drifts up.

POSSIBLE CAUSE

Sensor low potential (-p) lead is open.

PROBLEM

Display reads "OPEN"

POSSIBLE CAUSE

Sensor element is open or either current lead is open.

PROBLEM

Temperature readings are incorrect when compared to a known temperature.

POSSIBLE CAUSE

Check resistance reading against your RvsT table. If resistance is correct and temperature is incorrect, then an error was made in programming. If both resistance and temperature readings are incorrect, check calibration of the instrument (see Section 4). Also check to make sure that the calibration coefficients are for the sensor that you are using.

PROBLEM

Instrument reads error while programming data into EEPROM.

POSSIBLE CAUSE

If after three attempts without success, the EEPROM is probably defective. Contact the factory for instructions.

PROBLEM

Instrument works OK, but will not operate from the remote terminal (options 14 & 15).

POSSIBLE CAUSE

Loose remote card (see Figure 2). Loose wire, connecting remote card to the rear of instrument. Loose or broken interface cable. On RS-232C models (option 14) check Baud rate, word length, parity and stop bit requirements; reprogram if necessary. On IEEE-488 models (option 15) check to make sure the address has been programmed correctly.

PROBLEM

Display reads on of the following messages:

PROG 1 PROG IEEE PROG 232

POSSIBLE CAUSE

These messages mean that a programmed variable has changed. See paragraph 2.5, "Checksum Verification of Programmed Variables".

7. PARTS LIST (MODELS 4221C & 4222C)

NOTE: THE FOLLOWING PARTS LIST INCLUDES ALL POSSIBLE COMPONENTS THAT COULD BE INSTALLED, SOME OF THESE COMPONENTS MAY NOT BE INSTALLED FOR YOUR MODEL.

MASTER P.C. BOARD

SYMBOL	DESCRIPTION	MFG'R	MFG'R P/N	INSTRULAB P/N
_	P.C. Board with all components assembled and tested			158C0371B
CAPACITORS:				
C1	4700uf.@16	Nichicon	UVX1C472MHA	131-0155
C2,3	220uf.@35 VDC	Nichicon	UVX1V221MPA	131-0108
C4,7,8,11, 40,42,43, 44,46,47, 49,50,51, 52,60,61	1uf.@35 VDC	Kemet	T350A105M035AS	131-0103
C5,12,32	33uf.@10 VDC	Kemet	T354F336M010AS	131-0125
C6,13,14,15 17,18,19,20, 21,22,23,26, 27,28,30,31, 33	.1uf.@100	AVX	SR205E104MAA	131-0161
C9,10,29	6.8uf.@35	Kemet	T354F685M035AS	131-0126
C16	.01uf.@100 VDC	Arco	TCP-R01	131-0109
C24,25	33pf.@1000 VDC	Arco	CCD330	131-0137
C41	100pf.@1000 VDC	Arco	CCD101	131-0117
C45	.1uf.@67 VAC	Electrocube	910B1C104K	131-0148
C48	1.0uf.@135 VAC	Electrocube	935B1C105K	131-0127
C53,54,55,56	12.0uf@100 VDC	Electrocube	230C1B126K	131-0151
C57	1.0uf.@100 VDC	Electrocube	230B1B105K	131-0146
C58	2.0uf.@100 VDC	Electrecube	230B1B205K	131-0147
C59	1000pf@25 VDC	Mallory	SXK210	131-0162

MASTER P.C. BOARD (Continued)

SYMBOL	DESCRIPTION	MFG'R	MFG'R P/N	INSTRULAB P/N
DIODES, RECTIFYING				
CR1,2,3,4, 5,6,7,			1N4002	140-0084-001
DIODES, SIGNAL				
CR11,12,22,23		Fairchild	1N914A	140-0040
DIODES, ZENER				
CR20,21		Fairchild	1N758A	140-0503
CR24,25		Motorola	1N5525B	140-0186
TRANSISTORS				
Q2	NPN	Motorola	MPS4124	140-0086
Q3,4,5	FET	Siliconix	J201	140-0039
Q6,7,8	FET	Siliconix	2N5486	140-0195
Q9,10,11,12	FET	Siliconix	J108	140-0078
RESISTORS				
1/4 W CARBON FILM 5%		R ohm	R25J	139-0162-ohms
R5,8,16,18		47K ohms		
R6		24K ohms		
R7,9,13,20,21		10K ohms		
R15,29,30		100K ohms		
R17		240K ohms		
R19		100 ohms		
R22,24,28,34,35		1K ohms		
R23		3.3K ohms		
R25		2.7K ohms		
R26,27,33,38		1 meg		

MASTER P.C. BOARD (Continued)

SYMBOL	DESCRIPTION	MFG'R	MFG'R P/N	INSTRULAB P/N
RESISTORS				
1/8 W METAL FILM 1%		Dale	CMF55 (RN55D)	139-0092
R31,49		100K ohms		
R32,36,39		1K ohms		
R37		24.9K ohms		
R39		100 ohms		
R40,42		1.47K ohms		
R41		909 ohms		
R43,46,48		6.19K ohms		
R44,45		75 ohms		
R50		10 ohms		
RESISTOR, Special				
R47	100.1 ohms+.05%	Vishay	S102K	139-0144
RESISTORS, SIP				
RP1,3	47K 9 resistors	Bourns	4610X-101-473	139-0430
RP2	47K 5 resistors	Bourns	4606X-101-473	139-0432
RP4	1.5K 4 resistors	Bourns	4608X-102-152	139-0434
RP5	1.5K 3 resistors	Bourns	4606X-102-152	139-0433
TRIMMERS				
R101	50K ohms	Bourns	3299W-1-503	153-0100
SWITCHES				
S2	Function	Tyco/Amp	435640-5	134-0057
S3	Digit Select	Schadow	D6 BK	134-0063
S4	Count	Schadow	D6 RD	134-0064
S5	Coef Select	Schadow	D6 Grey	134-0065

MASTER P.C. BOARD (Continued)

SYMBOL	DESCRIPTION	MFG'R	MFG'R P/N	INSTRULAB P/N
TRANSFORMER,	LOW EMI			149B0096
INTEGRATED CIRCUITS				
U2		SGS	M48Z12-150PCI	167-0222
U4,17		NSC	DM74HC74AN	167-0194
U5		NSC	*27C256	167-0226
			27C128	167-0207
U6,9		NSC	DM74HC08N	167-0190
U7		NSC	DM74HC86N	167-0195
U8		NSC	DM74HC573N	167-0221
U10		HARRIS	82C54	167-0186
U11		NSC	DM74HC138N	167-0197
U12		NSC	DM74HC00N	167-0187
U13		OKI	80C85	167-0184
U14		NSC	DM74HC02N	167-0188
U15		NSC	DM74LS139N	167-0174
U16,18		OKI	81C55	167-0185
U20		A.D.	OP27EP	157-0205
U21		NSC	LM311N	157-0173
U22		A.D.	OP97EP	157-0183
U23		NSC	LF356N	157-0112
U24		NSC	LM393N	157-0206
U25,27		NSC	LM339N	157-0064
U26		A.D.	OP27GP	157-0233
U28		NSC	DM74HC32N	167-0193
U29		SILICONIX	DG403DJ	157-0204

*Programmed: Supply complete instrument model & serial number

MASTER P.C. BOARD (Continued)

SYMBOL	DESCRIPTION	MFG'R	MFG'R P/N	INSTRULAB P/N
VOLTAGE REGULATORS				
VR1, 4	+5V. VDC	Motorola	MC7805CT	157-0047
VR2	+15V. VDC	Motorola	MC7815CT	157-0089
VR3	-15V. VDC	Motorola	MC7915CT	157-0176
VR5	+12V. VDC	Motorola	MC78L12ACP	157-0209
VR6	-12V. VDC	Motorola	MC79L12ACP	157-0210
VR7	+5V. VDC	Motorola	MC78L05ACP	157-0110
XTAL	6.144 Meg. Hz.	M-tron	MP-1	140-0190
CONNECTORS				
J1	6 pin wafer	Molex	09-18-5061	169-0108
J3	44 pin header	Ap	929975-22	169-0124
J4	12 pin header	AP	929975-6	169-0122
J5	14 pin header	AP	929975-7	169-0122
PC TERMINAL BLOCKS				
2pt	interlocking	Phoenix Contact	1733415	170-0033

DISPLAY P.C. BOARD

SYMBOL	DESCRIPTION	MFG'R	MFG'R P/N	INSTRULAB P/N
—	P.C. Board with all components, assembled and tested			158B0372A
CAPACITORS				
C1,2	.001uF@500 VDC	Arco	CCD 102	131-0081
C3	33uF@10 VDC	Kemet	T354F336M010AS	131-0125
C4,5,7, 8,9,10	.1uF@100 VDC	AVX	SR205E104MAA	131-0161
C6	.047uF@100 VDC	Sprague	1C10X7R473K100B	131-0165
L.E.D.'s				
LD1,2,3, 4,5,6,7 8	Seven Segment	Qual. Tech.	MAN4910A	156-0007
LD9,10,11		Qual. Tech.	HLMP2400	156-0016
LD12		Qual. Tech.	HLMP2500	156-0017
LD13		Qual. Tech.	HLMP2300	156-0017
INTEGRATED CIRCUITS				
U1,2	Display Drivers	N.S.C.	MM5450N	167-0164
U3		Motorola	MC14490P	167-0251
U4		NSC	74HC74	167-0194
U5,6,7		T.I.	SN75451BP	167-0250
CONNECTORS				
P4	12 Pin	AP	929838-01-06	169-0121
P5	14 Pin	AP	929838-01-07	169-0121

DISPLAY P.C. BOARD (Continued)

SYMBOL	DESCRIPTION	MFG'R	MFG'R P/N	INSTRULAB P/N
RESISTORS				
	1/4 W CARBON FILM 5%	R ohm	R25J	139-0162
R1,2	15K			139-0162
R3,4,5, 6,7	270 to 390 ohm select			139-0162
RESISTOR, SIP				
RP1	330 ohms	Bourns	4608X-102-331	139-0434
SWITCHES, PC MOUNT				
SW1,2	"CHANNEL" "UNITS"	"E"SWITCH	320E1-1-2	134-0085

MISCELLANEOUS PARTS

Fuse	Buss	MDL 1/4A	136-0023
Fuse Holder	Littelfuse	345611	136-0024
Line Cord	Belden	17250B1-10	163-0091
Power Switch	Schadow	NE18	134-0072
Power Line Filter	Corcom	1ED2	134-0015
Volt Select Sw.	Schurter	SWA033.4501	134-0079

IEEE-488 P.C. BOARD

SYMBOL	DESCRIPTION	MFG'R	MFG'R P/N	INSTRULAB P/N
-	P.C. Board with all components assembled and tested			158B0326
CAPACITORS				
C1,3	33uf@10 VDC	Kemet	T354F336M010AS	131-0125
C2	.01uf@100VDC	Arco	TCP-R01	131-0109
RESISTORS, 1/4 W CARBON FILM 5%				
R1	10K	R ohm	R25J	139-0162
INTEGRATED CIRCUITS				
U1		T.I.	SN75161AN	167-0179
U2		T.I.	SN75160AN	167-0178
U3		T.I.	SN74LS04N	167-0128
U4		NAT'L. INSTR.	NAT9914APD	167-0180
CONNECTORS				
J6	26 pin header	FCI	52601-S26-4	169-0058
P3	44 pin conn.	AP	929838-01-22	169-0123

RS-232C P.C. BOARD

SYMBOL	DESCRIPTION	MFG'R	MFG'R P/N	INSTRULAB P/N
_	P.C. Board with all components assembled and tested			158B0327D
CAPACITORS				
C1,9	33uf@10VDC	Kemet	T354F336M010AS	131-0125
C2,4,6 7,8	.01uf.@100 VDC	Arco	TCP-RO1	131-0109
C3,5	6.8uf@35 VDC	Kemet	T354F685M035AS	131-0126
INTEGRATED CIRCUITS				
U1		N.S.C.	DS 14C88N	167-0151
U2		N.S.C.	DS 14C89AN	167-0152
U3		T.I.	TL16C450N	167-0153
VOLTAGE REGULATORS				
VR1	+12V. Reg.	Motorola	MC 7812CT	157-0160
VR2	-12V. Reg.	Motorola	MC 7912CT	157-0161
CONNECTORS				
J6	26 pin header	FCI	52601-S26-4	169-0058
P3	44 pin connector	AP	929838-01-22	169-0123

ANALOG OUT (WHEN SUPPLIED WITH IEEE-488) P.C. BOARD

SYMBOL	DESCRIPTION	MFG'R	MFG'R P/N	INSTRULAB P/N
-	P.C. Board with all components assembled and tested			158C0349A
CAPACITORS				
C4	.1uf.@50 VDC	Sprague	1C25Z5U104M050B	131-0166
C5,7	6.8uf.@35 VDC	Kemet	T354F685M035AS	131-0126
C6,8,9,10	.01uf.@100 VDC	Arco	TCP-RO1	131-0109
RESISTORS :				
	1/8W	Dale	CMF55 (RN55D)	139-0092
R2	24.3K ohms			
R3	15K ohms			
R4,5	453K ohms			
RESISTORS, SIP:				
RP1	47K ohms	Bourns	4610X-101-473	139-0430
TRIMMERS :				
R101	2K ohms	Bourns	3006P-1-202	135-0035

ANALOG OUT (WHEN SUPPLIED WITH IEEE-488) P.C. BOARD
(continued)

SYMBOL	DESCRIPTION	MFG'R	MFG'R P/N	INSTRULAB P/N
INTEGRATED CIRCUITS:				
U5		T.I.	SN74HC573	167-0221
U6		T.I.	SN74HC10	167-0220
U7		P.M.I.	PM7542HP	157-0219
U8		T.I.	SN74HC74	167-0194
U9		Siliconix	DG444	157-0232
U10,11		ADI	OP97EP	157-0183
VOLTAGE REGULATORS:				
VR1	+12V. Reg.	Motorola	MC78L12ACP	157-0209
VR2	-12V. Reg.	Motorola	MC79L12ACP	157-0210
VR3	+2.5V. Ref.	N.S.C.	LM385Z-2.5	157-0218
CONNECTORS:				
J7	3 pin	Molex	09-88-1031	169-0132

ANALOG OUT (WHEN SUPPLIED WITH RS-232C) P.C. BOARD

SYMBOL	DESCRIPTION	MFG'R	MFG'R P/N	INSTRULAB P/N
-	P.C. Board with all components assembled and tested			158C0357A
CAPACITORS:				
C10	.1uf.@50 VDC	Sprague	1C25Z5U104M050B	131-0166
RESISTORS:				
METAL FILM	1/8W 1%	Dale	CMF55 (RN55D)	139-0092
R2	24.3K ohms			
R3	15K ohms			
R4,5	453K ohms			
RESISTORS, SIP:				
RP1	47K ohms	Bourns	4610X-101-473	139-0430
TRIMMERS:				
R101	2K ohms	Bourns	3006P-1-202	153-0035

ANALOG OUT (WHEN SUPPLIED WITH RS-232C) P.C. BOARD
(continued)

SYMBOL	DESCRIPTION	MFG'R	MFG'R P/N	INSTRULAB P/N
INTEGRATED CIRCUITS:				
U3		T.I	TL16C450N	167-0153
U5		T.I.	SN74HC573	167-0221
U6		T.I.	SN74HC10	167-0220
U7		P.M.I.	PM7542HP	157-0219
U8		T.I.	SN74HC74	167-0194
U9		Siliconix	DG444	157-0232
U10, 11		ADI	OP97EP	157-0183
VOLTAGE REGULATORS:				
VR1	+12V Reg.	Motorola	*MC78L12ACP	157-0209
VR2	-12V Reg.	Motorola	*MC79L12ACP	157-0210
VR3	+2.5V Ref.	N.S.C.	LM385Z-2.5	157-0218
CONNECTORS:				
J7	3 pin	Molex	09-88-1031	169-0132

* (Note: These replace VR1 & VR2 on the RS-232C P.C. Board)